

USER MANUAL

UNIVERSAL LASER RECEIVER

- R.3CHS
- R.ULS.B
- R.ULS.CAN
- R.ULS.MM.CAN



This manual is an important part of your purchase. Please read it thoroughly before using your new equipment.

We recommend that you record details of your purchase here so that the information is readily available if you ever need to contact your supplier.

Serial number

Date of purchase

Purchased from

Telephone

Email

Published by:

MOBA Mobile Automation Australia Pty Ltd
90 Willandra Drive
Epping, 3076
Victoria, Australia

Copyright © MOBA Mobile Automation Australia Pty Ltd

MCE Lasers ® is a registered trademark of MOBA Mobile Automation Australia Pty Ltd

All rights reserved. No part of this manual may be reproduced in any form or by any means without prior written permission from the publishers.

March 2022

Stock number: OM.RULS

Document number: 012-01-000-17-001-09

Firmware version: ULS_V3.02, ULS_MM_V3.06_CAN



MCE Lasers was acquired by MOBA in 2018, bringing 40 years of Australian development and manufacturing together with MOBA's globally recognised and trusted expertise in mobile automation technology.



WARRANTY

STATEMENT OF LIMITED WARRANTY

MOBA Mobile Automation Australia Pty Ltd (MOBA Australia) warrants all equipment of its manufacture to be free of defects in material and workmanship for a period specified below. This warranty period is from the date of invoice. Items covered by this warranty are: sensors, transmitters, electronic levels, receivers, masts, control boxes, displays and accessories. All other components not manufactured by MOBA Australia but sold as part of the installation package, such as hydraulic or electrical components, hoses, fittings and clamps, will carry the original manufacturer's warranty.

Warranty period:

- Rotec laser levels: 2 years
- Rechargeable batteries: 90 days
- All other equipment: 1 year

MOBA Australia or its authorised service centre will repair or replace, at its option, any defective part or component of which notice has been given during the warranty period. A warranty registration card must be filled out properly and be on file with the MOBA Australia service department before warranty repair or replacement can be approved. If service in the field is necessary to repair machine-mounted equipment under warranty, MOBA Australia may authorize on-site repairs at no charge for parts and labour. Travel time, accommodation and other expenses incurred to and from the place where repairs are made will be charged to the purchaser at the prevailing rates. If warranty service can be done at a factory authorised service centre, the customer will pay only one-way freight charges.

Any evidence of negligence or abnormal use, accident, or an attempt to repair equipment by other than factory authorised personnel even when using MOBA Australia's certified or recommended parts, automatically voids the warranty.

The foregoing states the entire liability of MOBA Australia regarding the purchase and use of its equipment. MOBA Australia will not be held responsible for any consequential loss or damage of any kind.

This warranty is in lieu of all other warranties, except as set forth above, including any implied warranty of merchantability or fitness for a particular purpose, are hereby disclaimed. This warranty is in lieu of all other warranties, expressed or implied.

SAFETY INFORMATION

Please become familiar with the important safety information in this section. Improper use or installation of the MOBA Laserguide may result in personal injury or damage to the receiver unit.

- 1 Read and become familiar with the manufacturer's operating manual for your machine, including safety information, before installing or using your Laserguide receiver.
- 2 A construction site can be hazardous and working around heavy construction equipment can be dangerous. Always exercise extreme caution when on a construction site.
- 3 The Laserguide is externally mounted on your machine. Do not install or adjust the unit while your machine is running.
- 4 Do not let any part of the unit protrude into traffic or limit the visibility of the operator.
- 5 Always use eye protection when welding, cutting or grinding is being done on the machine.
- 6 Hydraulic lines can be under extreme pressure, even when the machine is not running. When working on or near hydraulic lines, protect yourself at all times and wear protective clothing.

Warning:

Do not weld near any hydraulic line or on any equipment while it is in operation. It is best to remove any electronic gear near a welding job.

Caution:

All mounting bracket welds must be strong and secure enough so as to prevent the Laserguide from vibrating excessively or from breaking at the weld while the machine is operating

- 7 Any external power supply must be rated between 12 and 24 Volts DC.

Caution:

Be sure your hands are dry before handling the machine battery terminals or power cables.

- 8 The internal battery pack of the Laserguide should be fully recharged before each use (internal battery models only).

Warning: Do not expose the internal batteries to intense heat.

CONTENTS

1. Introduction	6
1.1 Product Versions	6
1.2 Principles of Operation	7
1.3 Operational Features	7
1.4 Physical Features	8
2. Operating the Laserguide	9
2.1 Stand Alone	9
2.1.1 Powering Up	9
2.1.2 Setting the Centre Band Resolution	10
2.1.3 Adjusting the LED Cluster Brightness	11
2.1.4 Charging the Internal Batteries (R.ULS.B Only)	12
2.2 Operating with a MOBA Display Panel (R.ULS.B Only)	13
2.2.1 BT Connectivity Setup	14
2.3 Operating with a MOBA Control Panel	15
3. Installing and Using the Laserguide	17
3.1 Mounting the Laserguide	17
3.1.1 Bulldozer or Scraper Blade	17
3.1.2 Excavator or Backhoe	18
3.2 Setting Up the Laserguide	19
3.3 Reading the LED Display	20
3.3.1. Memory	21
4. Troubleshooting	22
5. Accessories	23
6. Specifications	24

1. INTRODUCTION

The MOBA Laserguide is a rugged, multipurpose electronic instrument designed to assist in alignment, excavation and land levelling work. When used with a compatible laser transmitter (such as the MOBA LS.230 grade laser), the MOBA Laserguide can help you:

- significantly reduce your work time, and
- dramatically improve the quality of your work by assisting you to deliver perfect accuracy each time.

1.1 Product Versions

The MOBA Laserguide is available in different versions:

R.3CHS	5-channel receiver for operation with a control panel (single side) or as a stand-alone unit. Requires external power supply. Supports continuous and pulsing hydraulic output.
R.ULS.B	5-channel receiver for operation with a control panel (single or dual side) or a display panel or as a stand-alone unit. Can work with external power supply or internal battery. Supports proportional, continuous or pulsing hydraulic output. Has BT for communicating with display panel. Uses CAN communication protocol for communicating with control panel.
R.ULS.CAN	5-channel receiver for operation with a control panel (single or dual side) or as a standalone unit. Requires external power supply. Uses CAN communication protocol for communicating with control panel. Supports proportional, continuous or pulsing hydraulic output.
R.ULS.MM.CAN	5-channel receiver for operation with a control panel (single or dual side). Millimetre precision, requires external power supply. Uses CAN communication protocol for communicating with control panel. Supports proportional, continuous or pulsing hydraulic output. Supports offsetting of 'on grade' position.

TABLE 1

1.2 Principles of Operation

The Laserguide is designed to operate in conjunction with rotating lasers of all types which generate invisible or visible light. The unit detects the laser beam and provides a highly visible indication of the height of the blade or bucket of the machine relative to the reference plane delineated by the rotating laser beam. The features and versatility of the Laserguide allow it to be adapted to many different types of machines and applications.

The unit incorporates sophisticated electronic circuitry which allows it to offer an exceptional operating range (up to 700 metres) while maintaining the resolution for the centre band (accuracy). There are user selectable settings for centre band resolution and display brightness and also selectable modes of operation. All user selected settings are retained at power down and are automatically restored the next time the unit is powered up.

Laserguide settings can be controlled through a MOBA control panel (e.g. CB.D2.CAN), a MOBA display panel (e.g. DB.UNI.PRO, R.ULS.B only), a remote control (optional) or through integrated buttons (R.ULS.B only).

1.3 Operational Features

The MOBA Laserguide exhibits the following features:

1. Simple user interface with highly visible LED clusters to indicate bucket or blade position relative to target.
2. Rugged construction able to withstand harsh operating environments.
3. Automatic compensation of errors induced by vibration.
4. Operation from internal batteries that can be fast charged (R.ULS.B model only).
5. User selectable resolution (accuracy) for 'ON GRADE'.
6. Automatic saving and restoration of user selected settings.

1.4 Physical Features

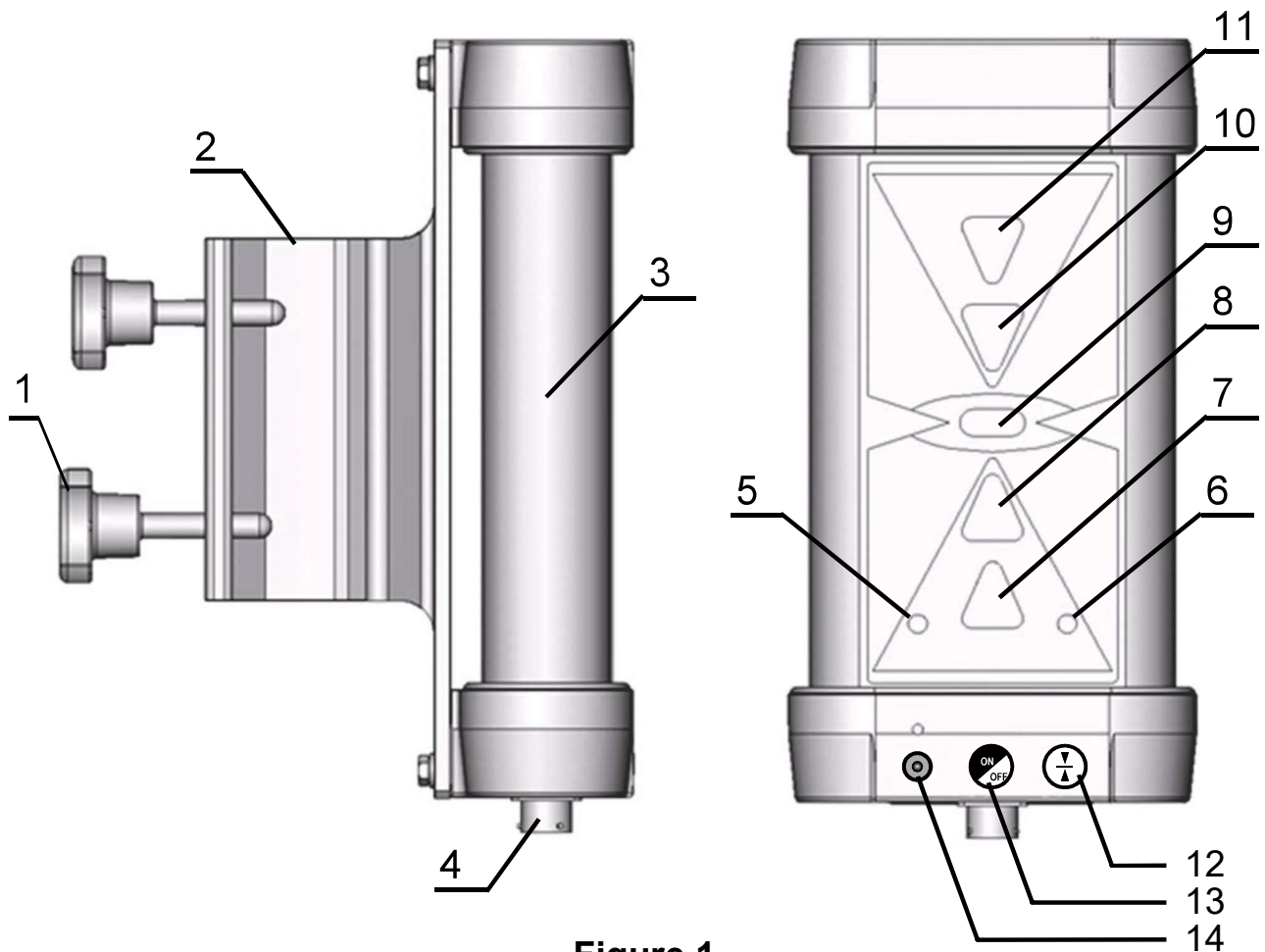

Figure 1

1. Clamping screw	8. Bottom-centre LED cluster
2. 360° mount	9. Centre LED cluster
3. Receiving area	10. Top-centre LED cluster
4. Military connector	11. Top LED cluster
5. Multi colored charging LED (R.ULS.B only)	12. Centre Band Button (R.ULS.B only)
6. Green Power On LED	13. ON/OFF Button (R.ULS.B only)
7. Bottom LED cluster	14. Charging socket (R.ULS.B only)

TABLE 2

2. OPERATING THE LASERGUIDE

The Laserguide can be operated in 3 different modes:

1. Stand alone.
2. Using a MOBA display panel (e.g. DB.UNI.PRO).
3. Using a MOBA control panel (e.g. CB.D2.CAN).

2.1 Stand Alone

The Laserguide can work as purely a visual guide for manual control of a blade or bucket by using it in standalone fashion. In this mode of operation, the machine operator manually adjusts the bucket or blade position in response to the Laserguide's directional indications to bring the bucket or blade to 'On-Grade'.

In Standalone operation, the Laserguide works with default centre band (accuracy) and LED brightness settings. An optional remote control can be supplied if required for changing these settings. Model R.ULS.B allows changing of settings via its own two-button interface.

2.1.1 Powering Up

To power up, simply connect the military connector (4) at the base of the unit to an external 12-24V DC power source using the supplied power cable. Normally, the machine's battery acts as the external power source. Do not connect to a power source that may exhibit big voltage spikes (such as the ignition) as this may damage the Laserguide and void warranty.

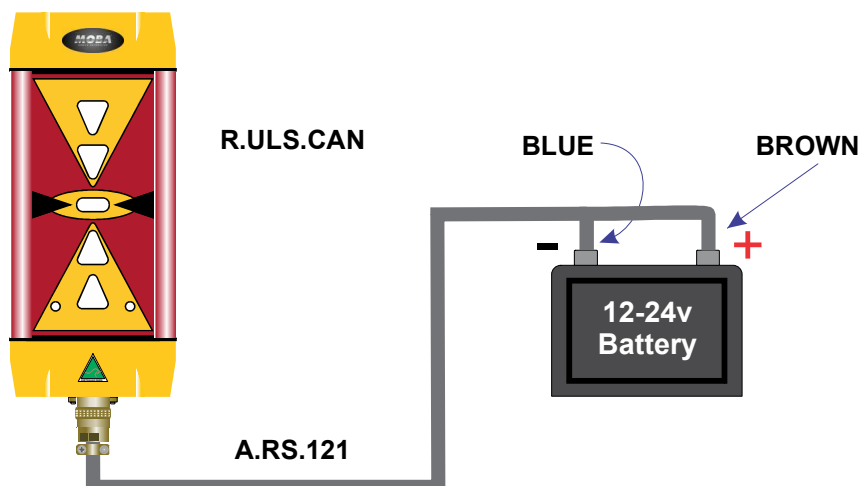

Figure 2

For internal battery model R.ULS.B, simply switch the unit on using the On/Off button (13) or alternatively connect the military connector to an external power source using an optionally supplied power cord.

On power up, the green Power On LED (6) will light to indicate the Laserguide is powered and the LED clusters will flash in sequence from top to bottom as part of initialisation. At completion of the sequence, the three inner LED clusters (8, 9 and 10) will briefly light in a particular pattern to indicate the current centre band setting. Table 3 in section 2.1.2 shows the centre band setting corresponding to each illumination pattern.

For model R.ULS.B, if powering up using the ON/OFF button, the Power On LED will flash to indicate when in low internal battery condition. If the internal battery is too flat the unit will not power on at all. Recharge the unit or power externally through the military connector.

2.1.2 Setting The Centre Band Resolution

Using the optionally supplied remote control or through the Laserguide's own button interface (R.ULS.B only), the Centre Band setting can be changed using the Centre Band button (12). Three settings are available, from most accurate to least: Fine, Medium and Wide. Each press of the button steps through these options.

To indicate the Centre Band setting selected, the three inner LED clusters (8, 9 and 10) briefly illuminate in a particular pattern when the Centre Band button is pressed. Table 3 shows which pattern corresponds to each setting.



	LED CLUSTERS LIT	CENTRE BAND RESOLUTION
	Centre LED cluster	FINE
	Top-centre and bottom centre LED clusters	MEDIUM
	Three centre LED clusters	WIDE

TABLE 3

2.1.3 Adjusting The LED Cluster Brightness

Use the Brightness button on the optionally supplied remote control to step through five different brightness levels. Each brightness level is shown by briefly flashing the LED clusters at a different intensity with each press of the button.

For R.ULS.B, the brightness can additionally be changed using its own button interface:

1. Power up using the ON/OFF button (13). Wait for initialisation phase to finish.
2. Press and hold the Centre Band button (12).
3. Press and release the ON/OFF button (13) repeatedly to step through the settings.

2.1.4 Charging the Internal Batteries (R.ULS.B only)

The standard R.ULS.B kit includes a charger that operates from 240 V AC mains. Optional cords can be purchased as accessories to charge the unit from either an external 12-24 V DC power supply such as a vehicle's 12V battery or through a vehicle's cigarette lighter outlet.

To charge the internal batteries from AC mains:

1. Plug the DC plug of the MOBA Battery Charger into the charging socket (14) on the front of the unit.
2. Plug the power cord of the MOBA Battery Charger into a mains outlet and switch on the mains power.
3. The Charging LED will light up in amber to indicate the unit is charging. When the LED turns to green, the charging cycle is complete. Red LED light indicates a fault (see troubleshooting, section 6).

To charge the internal batteries using the optional cords:

1. Plug the DC plug of the cords into the charging socket (14) on the front of the unit.
2. Connect the other end of the cords to either a machine's or vehicle's 12-24 V DC battery or to its cigarette lighter outlet.

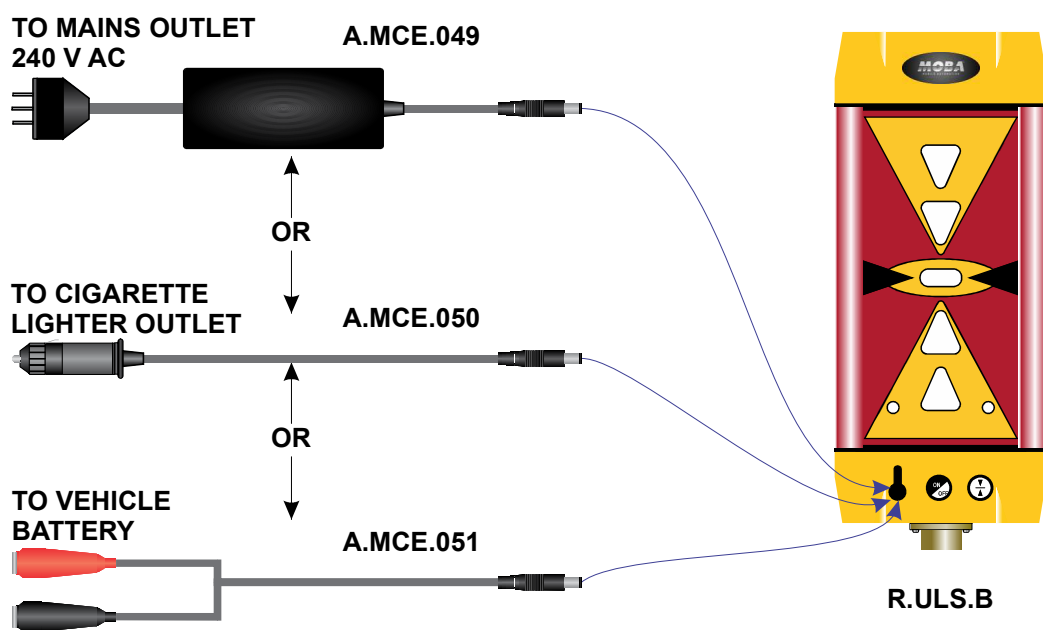

Figure 3

2.2 Operating With A MOBA Display Panel (R.ULS.B Only)

A display panel such as the DB.UNI.PRO is an accessory that allows the Laserguide to be used when it is not in the direct view of the machine operator. The Laserguide's LED indications are mirrored by the display panel which is placed conveniently close to the machine operator for direct line of sight. The machine operator can then manually adjust the blade or bucket position to achieve 'On-Grade'.

The DB.UNI.PRO has the following features:

1. BT for wireless communication with the R.ULS.B.
2. Five LED clusters that mirror the five R.ULS.B LED clusters for directing to target.
3. Is powered by connecting to an external 12-24V DC power source such as directly to the machine's 12V battery or to its cigarette lighter outlet.
4. A simple three-button interface: ON/OFF, Centre Band Select and Brightness Select
 1. ON/OFF – To switch the DB.UNI.PRO on or off
 2. Centre Band Select – To set the accuracy (Centre Band) of the R.ULS.B to Fine, Medium or Wide (Fine most accurate, Wide least accurate). Each press steps to the next setting. Current setting is indicated by the lit LED next to the words FINE, MEDIUM or WIDE.
 3. Brightness Select – To set the brightness of the DB.UNI.PRO LEDs. Five settings are available. Each press steps to the next setting.

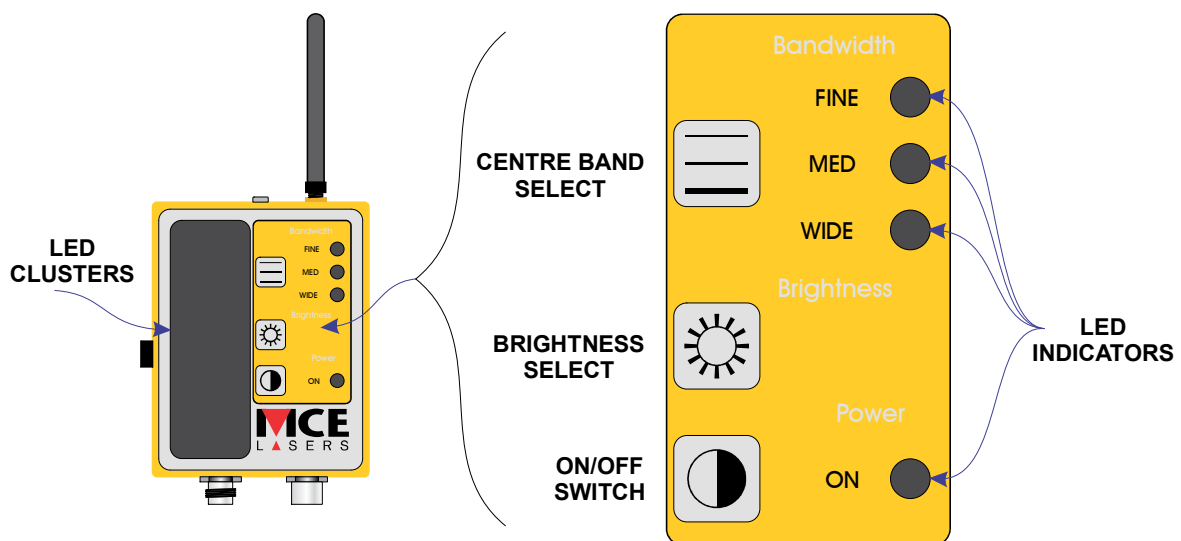

DB.UNI.PRO

Figure 4

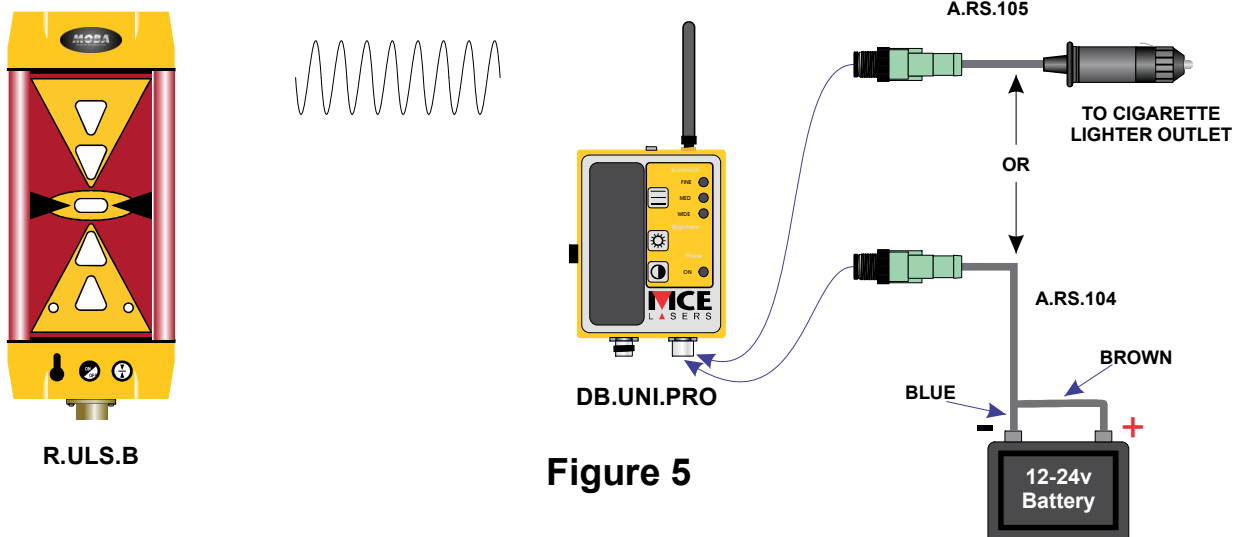

Figure 5

2.2.1 BT Connectivity Setup

The R.ULS.B is normally paired with the DB.UNI.PRO from factory when the two are bought together. This means that simply switching both on when near each other is all that is required for establishing communication between the two. However, in cases where the DB.UNI.PRO is bought at a later stage or when there is a problem establishing communication, the following procedure may have to be used to pair the two:

1. Ensure the DB.UNI.PRO and R.ULS.B are near each other.
2. Switch on the R.ULS.B, switch off the DB.UNI.PRO.
3. Press and hold the On/Off button on the DB.UNI.PRO for 10 seconds until a second beep. A progressive LED arrow bar will begin to flash to indicate the DB.UNI.PRO is in BT configure mode.
4. After a short period, two LED straight bars will appear on the DB.UNI.PRO, flashing in alternate sequence to show the BT is being setup and that the instrument is in search mode.
5. Two LED straight bars will flash together on the DB.UNI.PRO to show the BT is setup and an active device has been found and is in progress of pairing. After a short period, the DB.UNI.PRO will start to communicate with the R.ULS.B.
6. If the setup fails at any stage, an X will flash on the DB.UNI.PRO. Repeat the above steps.
7. If setup fails again, switch off the R.ULS.B and then press and hold the switch button on the R.ULS.B for 5 seconds until all five lights light up. Repeat steps 2 to 5.

2.3 Operating With a MOBA Control Panel

A range of MOBA control panels are available, such as the CB.D2.CAN, the DUO2.CAN and the CB.2001. Each one offers different capabilities in terms of the number of control sides available, the types of hydraulic valves controlled, the combinations of connecting sensors and electric masts and the degree of configurability.

In general, each MOBA control panel has all the functions available with display panels plus:

1. Electrical output for driving solenoids of hydraulic valves.
2. Capacity to automatically control the blade or bucket of a machine to bring it to 'On-Grade'.
3. Capacity for the operator to manually move the blade or bucket using buttons or switches on the control panel or through an optional joystick. The operator can use a combination of manual and automatic control if required.

When used in conjunction with a MOBA control panel, the Laserguide can automatically control earth moving operations such as for land levelling. The control panel integrates with the machine's hydraulic system and uses the electrical input from the Laserguide to control the machine's bucket or blade position to bring it 'On-Grade'. This is done by activating electrically operated solenoid valves in the machine's hydraulic system.

The Laserguide connects to MOBA control panels, sometimes indirectly through junction boxes, by cable attached to the military connector at the base of the unit. See Figure 6 for examples of control panel setups using the Laserguide. Contact MOBA Australia or a local representative for advice on the control panel model and setup most suited to your needs.

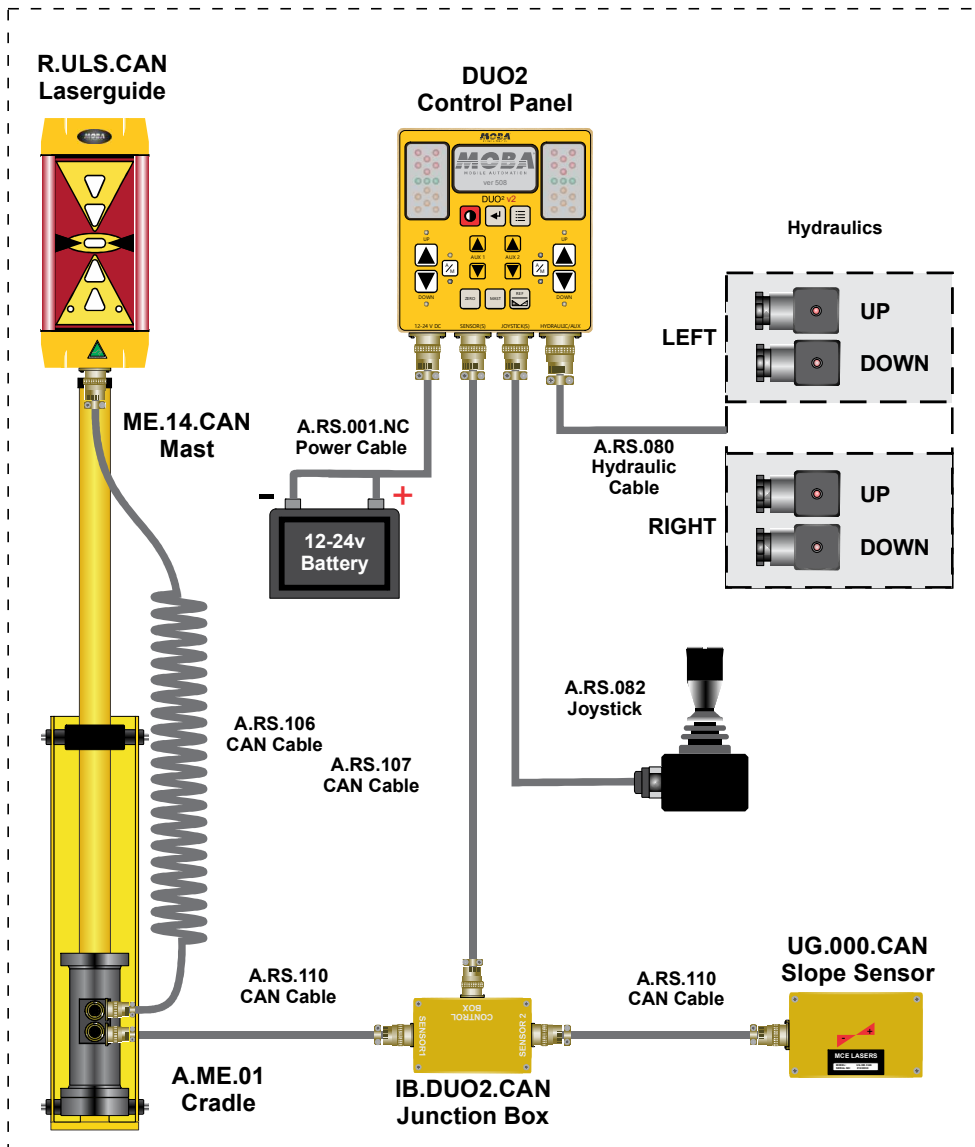
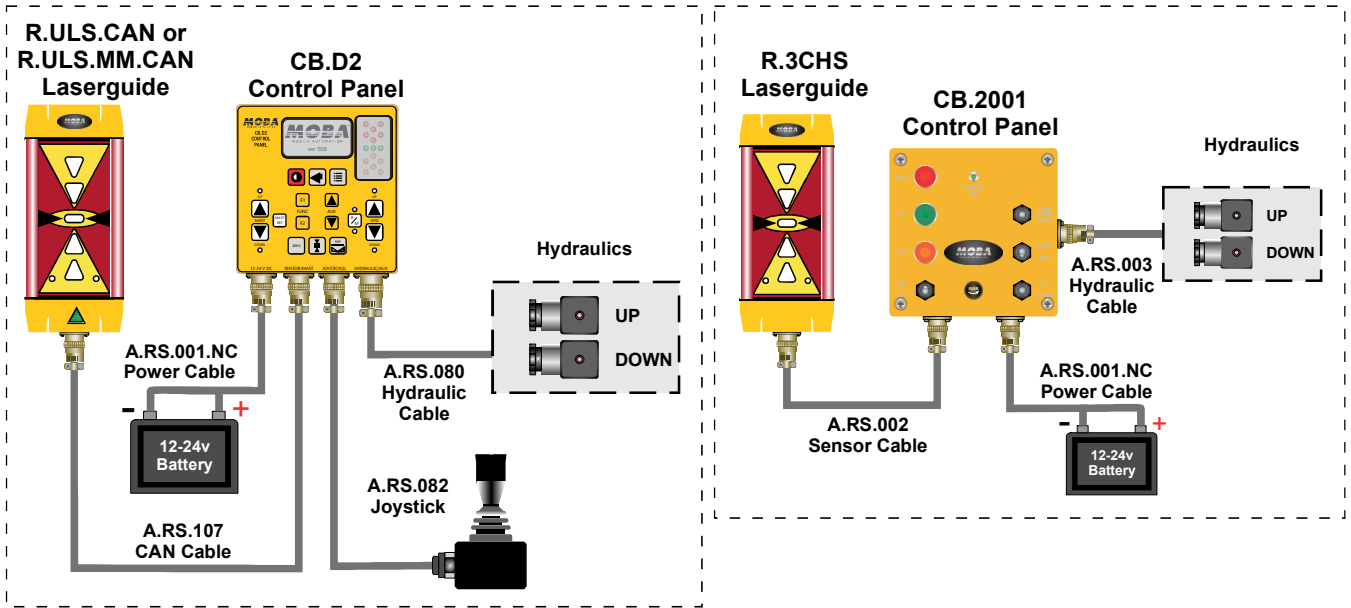

Figure 6

3. INSTALLING AND USING THE LASERGUIDE

3.1 Mounting the Laserguide

The general principle is to mount the Laserguide to a 52 mm or smaller diameter post which is fixed to the machine. The post should be vertical to work with a laser beam operating in the horizontal plane or horizontal to work with a laser beam operating in the vertical plane.

The post must be attached in a manner that allows the operator to maintain a relationship between the machine and the laser beam. Two examples are provided here to illustrate the principles involved, one using a vertical post mounted on a bulldozer blade and one using a vertical post attached to the side of an excavator dipper arm.

3.1.1 Bulldozer or Scraper Blade

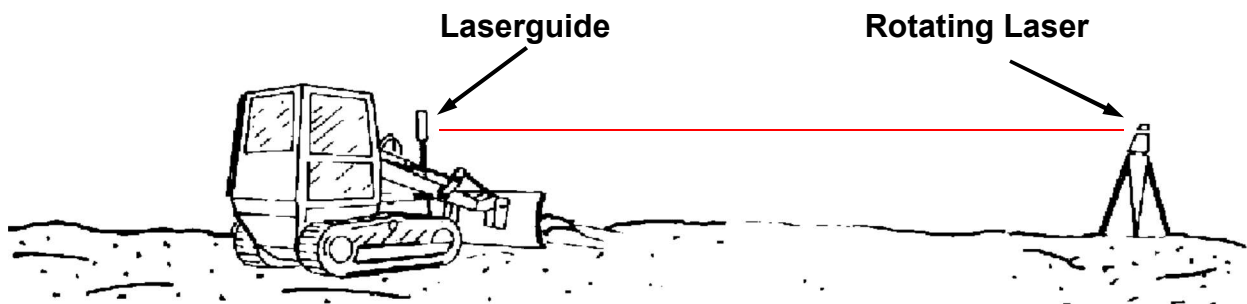

Figure 7

When the Laserguide is mounted on a bulldozer or a scraper blade, it can assist the operator in keeping the blade at the proper elevation during earth moving operations. The LED display of the Laserguide will indicate if the cutting edge of the blade is within the desired "on-grade" zone or not. If the blade is not in the correct position, the Laserguide will indicate in which direction the blade must be moved to regain the desired on-grade position. The operator can move the blade manually according to the signals provided by the Laserguide or when it is integrated into the machine's hydraulic controls through a control panel, the Laserguide can directly control the position of the blade.

Refer to section 3.2 for assistance on setting up the Laserguide before commencing any earth moving work. See section 3.3 for assistance in interpreting the signals displayed by the Laserguide.

3.1.2 Excavator Or Backhoe

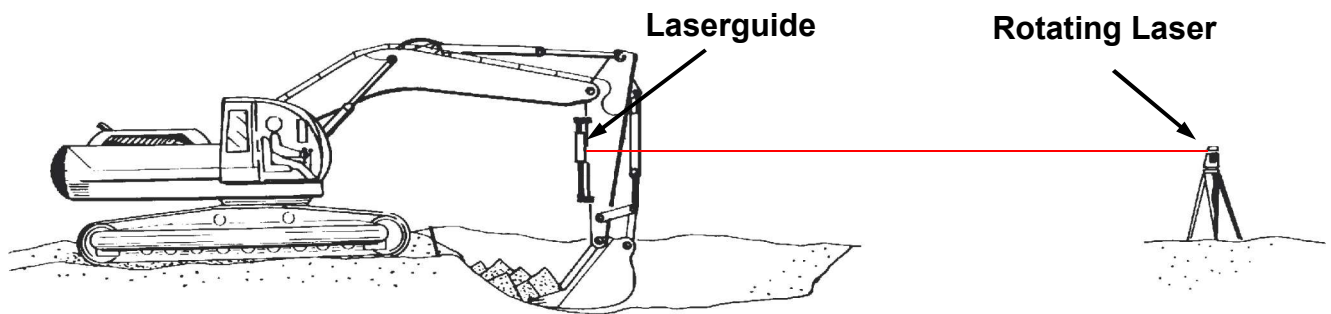

Figure 8

When the Laserguide is mounted on an excavator or backhoe, it can assist the operator in keeping the depth of cut correct during earth moving operations. The LED display of the Laserguide will indicate if the cutting edge of the bucket is within the desired "On-Grade" zone or not. If the bucket is not cutting at the correct depth, the Laserguide will indicate in which direction the bucket must be moved to regain the desired depth of cut.

The operator can adjust the cut manually according to the signals provided by the Laserguide.

Refer to section 3.2 for assistance on setting up the Laserguide before commencing any earth moving work. See section 3.3 for assistance in interpreting the signals displayed by the Laserguide.

3.2 Setting Up the Laserguide

These instructions are for operating with a laser beam rotating in the horizontal plane, typified by grader blades or excavator buckets. Your application may be different.

STEP	COMMENTS
Set the cutting edge of the blade or bucket at the desired "on - grade" position.	<p>The "on-grade" position will be some existing reference, perhaps where work last terminated.</p> <ol style="list-style-type: none"> 1. The cutting edge of the blade should be made to rest at some point which is known to be at the correct elevation. 2. The dipper stick of a backhoe or excavator should be within 5° of true vertical with the bucket "curled" to a readily repeatable position. 3. The lowest point of the bucket should be brought to rest at a point known to be at the correct elevation, perhaps at the bottom of an existing trench.
Set up the laser transmitter.	<p>The laser transmitter should be set up so that the plane swept by the rotating laser beam is correctly oriented (often horizontal) and intersects with the vertical post to which the Laserguide is mounted.</p> <p>Ideally you should be able to move the Laserguide up and down the vertical post to utilize the entire reception range.</p> <p>If the entire reception range cannot be used, raise or lower the laser transmitter until it can be used.</p>
Fit the Laserguide to the vertical post.	Back-off the clamping screws until the 360° mount passes over the vertical post.
Move the Laserguide up and down the vertical post until the central LED cluster indicates the unit is "On-Grade".	<div style="display: flex; align-items: center;">  <div style="margin-left: 20px;"> <p>When the central LED cluster is lit the laser beam is striking the Laserguide at the "On-Grade" position. For more information see section 3.3 of this manual.</p> </div> </div>
Tighten both clamping screws	Do not use a wrench to tighten the clamping screws.

TABLE 4

3.3 Reading The LED Display

LED CLUSTER LIT	MEANING
NONE	The laser beam is not striking the Laserguide. Adjust the bucket /blade up or down to locate the beam. If the beam can't be located, may need to adjust the transmitter up or down and repeat setup (section 3.2)
Top or bottom LED cluster flashing SLOWLY	The laser beam has gone past the top most or bottom most section of the Laserguide's receiving area. Move the bucket/blade in the direction indicated by the slowly flashing cluster. See also section 3.3.1.
Top and/or top-centre LED clusters flashing RAPIDLY	The bucket/blade is too high, adjust downwards.
Top-centre and centre LED clusters flashing RAPIDLY	The bucket/blade is slightly above grade, adjust downwards.
Centre LED cluster flashing RAPIDLY	The bucket/blade is on grade.
Bottom centre and centre LED clusters flashing RAPIDLY	The bucket/blade is slightly below grade, adjust upwards.
Bottom and/or bottom-centre LED clusters flashing RAPIDLY	The bucket/blade is too low, adjust upwards.

TABLE 5

3.3.1 Memory

If during normal operation, the laser beam goes past the top or bottom most sections of the Laserguide's receiving area, the last flashing LED cluster will continue to flash slowly.

For example:

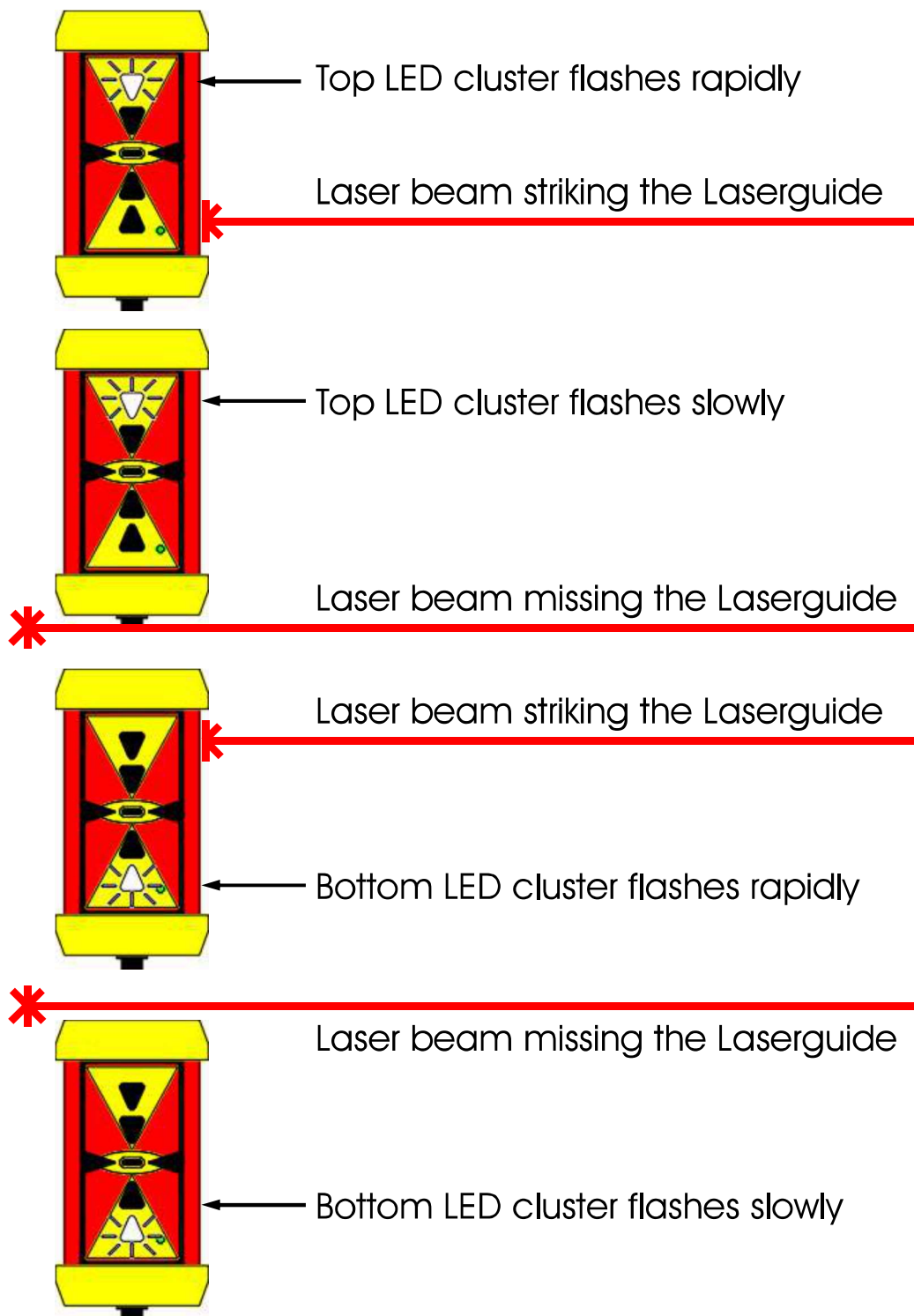

Figure 9

4. TROUBLESHOOTING

The MOBA Laserguide is reliable in operation and under normal circumstances the most common cause of any problem is a low or flat battery.

SYMPTOM	POSSIBLE CAUSE / COURSE OF ACTION
Laserguide is not operating	<ol style="list-style-type: none"> 1. The Laserguide is not powered up. <ul style="list-style-type: none"> – Check cord connection. – Check external power source. 2. The On /Off switch has not been held down for sufficient time (1 second) (R.ULS.B). 3. The internal battery is flat (R.ULS.B). 4. The internal battery is no longer serviceable (R.ULS.B).
No Signal	<ol style="list-style-type: none"> 1. The Laserguide is not powered up. 2. The laser transmitter is not operating. 3. The laser beam is not striking the Laserguide.
Slow Flashing LED Cluster	<ol style="list-style-type: none"> 1. Slow rotatting laser - increase RPM. 2. Memory funtion (see section 3.3.1) 3. Low internal battery (R.ULS.B).
Flashing Green Power On LED (R.ULS.B)	Low internal battery – recharge the unit.
Red charging LED (R.ULS.B)	<ol style="list-style-type: none"> 1. The charging plug is not properly inserted into the charging receptacle. 2. The charger is not properly powered up. 3. The charger is faulty. 4. The battery is unserviceable. 5. The red LED is faulty.
No communication between DB.UNI.PRO and R.ULS.B.	<ol style="list-style-type: none"> 1. Ensure the two are within 10m of each other. 2. Ensure no other units are interfering. 3. Ensure DB.UNI.PRO has its antenna screwed on. 4. Pair again (see section 2.2.1)

TABLE 6

NOTE: The MOBA Laserguide must be serviced by an authorized service centre or by the manufacturer as explained in Warranty Statement on page 3 of this manual.

5. ACCESSORIES

The following accessories can be used in conjunction with the MOBA Laserguide.

ACCESSORY DESCRIPTION	R.ULS.B	R.3CHS	R.ULS.CAN	R.ULS.MM.CAN
CONTROL PANEL	CB.D2.CAN DUO2.CAN	CB.2001	CB.D2.CAN DUO2.CAN	CB.D2.CAN DUO2.CAN
DISPLAY PANEL	DB.UNI.PRO	-----	-----	-----
POWER CORD	A.RS.121	A.RS.022	A.RS.121	-----
90° MAGNETIC BRACKET	A.RS.042	A.RS.042	A.RS.042	A.RS.042
BATTERY CHARGER 100-240 V AC/12 V DC 3.5A	A.MCE.049	-----	-----	-----
CIGARETTE LIGHTER CORD FOR BATTERY CHARGING	A.MCE.050	-----	-----	-----
CORD WITH ALLIGATOR CLIPS FOR BATTERY CHARGING	A.MCE.051	-----	-----	-----
HARD CARRY CASE	A.140.043.B	A.140.043.B	A.140.043.B	A.140.043.B
IR REMOTE CONTROL (FOR STAND-ALONE OPERATION ONLY)	YES	YES	YES	-----

TABLE 7

6. SPECIFICATIONS

	R.3CHS	R.ULS.B	R.ULS.CAN	R.ULS.MM.CAN
Internal power supply	N/A	LiPo Battery 3.7 V DC	N/A	N/A
Battery operating time	N/A	15 HRS	N/A	N/A
Battery charging time	N/A	5 HRS	N/A	N/A
Low battery indication	N/A	Power On LED Flashing	N/A	N/A
Battery charging indication	N/A	Charging LED Amber	N/A	N/A
Battery charged indication	N/A	Charging LED Green	N/A	N/A
Charging fault indication	N/A	Charging LED Red	N/A	N/A
Beam Reception area	196 mm			256 mm
Size	300 x 150 x 70 mm			390 x 150 x 70 mm
Weight	2.9 kg (inc. bracket)			3.6 kg (inc. bracket)
Mounting post diameter	35 mm to 52 mm			
Shock protection	YES			
Waterproof	YES			
Receiving Range ¹	700m radius			
Power ON indication	Green LED			
External Power Supply Voltage Range	12-24 V DC			
Automatic Shutdown	1 hour after the last detected laser beam			
Settings Memory	All settings are retained when the Laserguide is powered down and restored when it is powered up.			
Stand-alone Operation	YES			NO
Centre Band Resolution ²	Fine, Medium & Wide options	Fine, Medium and Wide options when working stand-alone. ±42mm to ±30mm when connected to a panel in increments of 1mm.		±1mm to ±30mm in increments of 1mm

TABLE 8

1) Tested with MOBA LS.230.E laser transmitter.

2) The actual resolution (accuracy) represented by terms FINE, MEDIUM, WIDE or by the value selection (when working with a control panel) will vary because of factors such as: reception range, type of laser transmitter and atmospheric conditions affecting the laser beam. Typically at a distance of 100m, with an LS.230.E laser transmitter, FINE = ±4mm, MEDIUM = ±16mm and WIDE = ±22mm.

MOBA Australia reserves the right to change specifications without notice.



MOBA MOBILE AUTOMATION AUSTRALIA PTY LTD

ABN - 866 279 713 68

90 Willandra Drive, Epping, Victoria, Australia 3076

Ph: +61 3 9357 0055

www.moba-automation.com.au