

DUO2 v2

DUAL MACHINE CONTROL PANEL WITH AUXILIARY OUTPUT

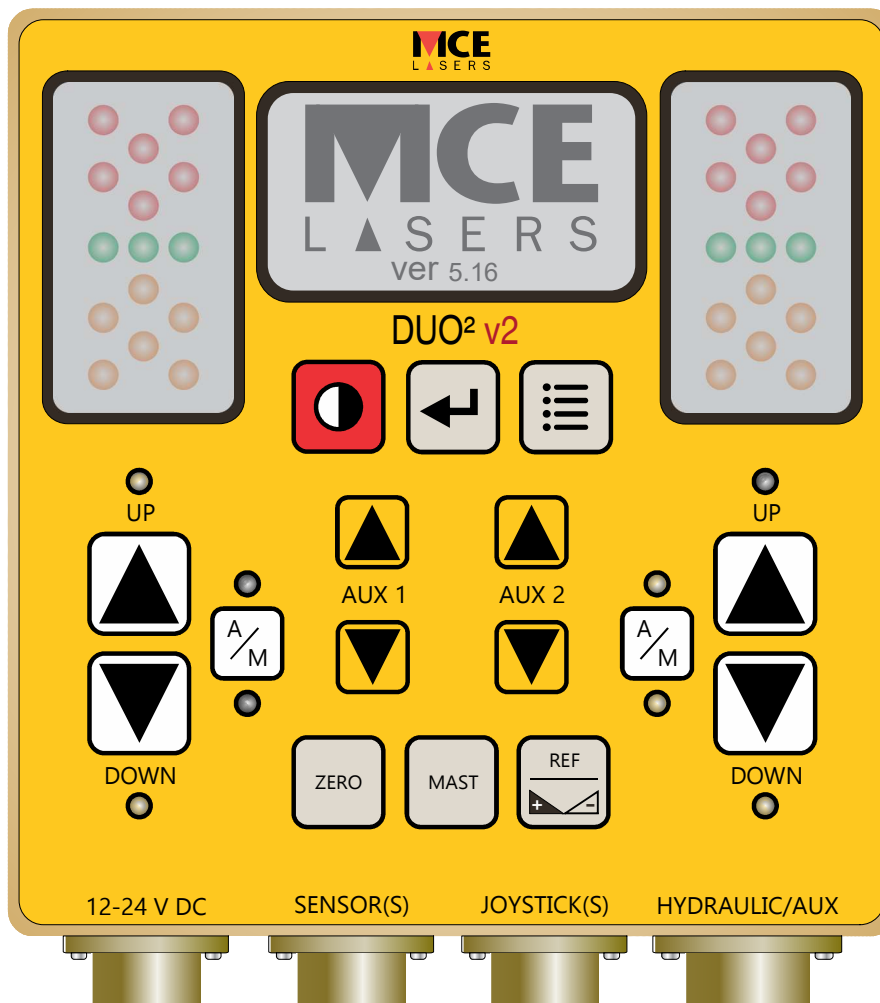

OPERATOR'S MANUAL





This manual is an important part of your purchase. Please read it thoroughly before using your DUO2 System.

We recommend that you record details of your purchase here so that the information is readily available if you ever need to contact your supplier.

Serial Number _____

Date of Purchase _____

Purchased from _____

Telephone _____

Facsimile _____

Email _____

Published By:

MOBA Mobile Automation Australia Pty Ltd
90 Willandra Drive
Epping 3076
Victoria, Australia

Copyright © 2019 MOBA Australia

MCE Lasers ® is a registered trademark of MOBA Australia.

All rights reserved. No part of this manual may be reproduced in any form or by any means without prior written permission from the publishers.

July 2019

Stock number: OM.DUO2

Document number: 010-15-000-17-000-02



WARRANTY

STATEMENT OF LIMITED WARRANTY

MOBA Australia warrants all equipment of its manufacture to be free of defects in material and workmanship for a period of twelve months. This warranty period is twelve months from the date of invoice. Items covered by this warranty are: sensors, transmitters, electronic levels, receivers, masts, control boxes, displays and accessories. All other components not manufactured by MOBA Australia but sold as a part of the installation package, such as hydraulic or electrical components, hoses, fittings and clamps, will carry the original manufacturer's warranty.

MOBA Australia or its authorised service centre will repair or replace, at its option, any defective part or component of which notice has been given during the warranty period. A warranty registration card must be filled out properly and be on file with the MOBA Australia service department before warranty repair or replacement can be approved. If service in the field is necessary to repair machine-mounted equipment under warranty, MOBA Australia may authorize on-site repairs at no charge for parts and labour. Travel time, accommodation and other expenses incurred to and from the place where repairs are made will be charged to the purchaser at the prevailing rates. If warranty service can be done at a factory authorised service centre, the customer will pay only one way freight charges.

Any evidence of negligence or abnormal use, accident or an attempt to repair equipment by other than factory authorised personnel even when using MOBA Australia's certified or recommended parts, automatically voids the warranty.

The foregoing states the entire liability of MOBA Australia regarding the purchase and use of its equipment. MOBA Australia will not be held responsible for any consequential loss or damage of any kind.

This warranty is in lieu of all other warranties, except as set forth above, including any implied warranty of merchantability or fitness for a particular purpose, are hereby disclaimed. This warranty is in lieu of all other warranties, expressed or implied.



TABLE OF CONTENTS

1. Product Overview	7
2. User Interface	8
2.1. Graphic Display	8
2.2. Key Functions	8
2.3. Key Legend	9
2.4. LED Indication	10
2.5. Sensor Lights	10
2.6. Configuration Menu	11
3. First Steps	12
3.1. Basic Setup	12
3.2. Cable Connections	13
3.3. Connecting DUO ²	13
3.4. Hydraulic Valve Configuration	14
3.5. Powering Up	18
3.6. Working Screen	18
3.7. Setting Up Hydraulics	19
3.7.1. Selecting Type of Hydraulics	20
3.7.2. Adjusting Settings for Hydraulic Response	21
3.7.2.1 General Settings for VO Hydraulics	22
3.7.2.2 General Settings for IO Hydraulics	23
3.7.2.3 General Settings for ON/OFF Hydraulics	24
3.7.3. Calibration - Hydraulics	25
3.7.3.1 Min Pulse Calibration (Hydraulics)	26
3.7.3.2 Max Pulse Calibration (Hydraulics)	27
3.7.4. Advanced Settings (Hydraulics)	28
4. Working with Panel	29
4.1. Manually Moving the Blade	29
4.2. Setting the Valve Control Mode	30
4.3. Grade to zero operation	31



TABLE OF CONTENTS (continued)

4.4. Reference, Offset & Set Target	32
4.4.1. To Select Reference	33
4.4.2. To Adjust Reference/Offset	33
4.4.3. To Transfer Current Sensor value into Reference/Offset	33
4.4.4. To Zero Reference/Offset value	34
4.5. Hydraulics L/R for slope sensor	34
4.6. Auxiliary Control	35
4.6.1 Auxiliary Keys Settings	35
5. Sensor Settings	36
5.1. General Sensor Settings	37
5.1.1. Response Adjustment	37
5.1.2. Dead Band Adjustments	38
5.1.3. Proportional Range Adjustment	39
5.1.4. Control Range Adjustment	39
5.1.5. Measurement Mode	40
5.1.6. Offset	40
5.1.7. Units	40
5.2. Calibrating Slope & Tracer Sensors	41
5.2.1 Before Calibrating Slope Sensor	41
5.2.2 Before Calibrating Tracer Sensor	41
5.3. Slope Sensor - Side Selection	43
5.4. LCD/LED Settings	43
5.4.1. LCD Backlight Settings	43
5.4.2. Backlight OFF/ON/AUTO Settings	44
5.4.3. LCD Brightnes	44
5.4.4. LCD Contrast	44
5.4.5. Reverse LCD	45
5.4.6. LED Brightness	45



TABLE OF CONTENTS (continued)

5.5 Mast Mode of Operation	46
5.5.1. Mast Working Screen	46
5.5.2. Mast Function Keys	46
5.5.3. Adjusting Mast Position	47
5.5.4 Relative Offset	48
5.5.4.1 Using the Panel Keys	48
5.5.4.2 Using Optional Joystick	49
6. GNSS Sensor	51
6.1. GNSS Working Screen	51
6.2 GNSS Function Keys	51
6.3 GNSS Job Type Selection and Setup	52
6.4 GNSS Auto Mode	53
7. Reset to System Default.....	54
8. Joystick Type	55
9. Practical Example.....	58

1. PRODUCT OVERVIEW

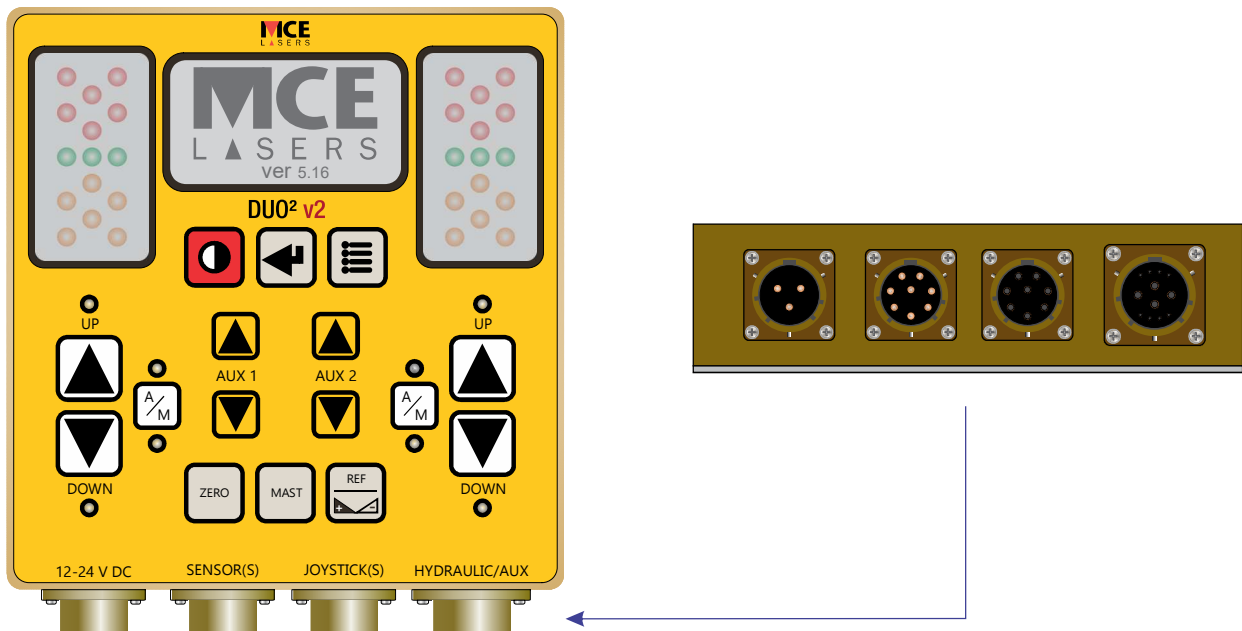

figure 1

The DUO2 is a control panel for dual machine control application. The DUO2 has a dual control for valve actuation and dual control for auxiliary valves. The system provides the user with the flexibility to independently use single or multiple valve control.

Information provided by the sensor is intelligently processed and applied to the valve control. System control status and sensor readings are shown in bigger fonts for easy viewing.

A clearly structured configuration menu enables the operator to set all necessary settings, from accuracy selection for control to the selection of different valve types to be used.

In addition a three-coloured 5 channel LED clusters on each side of the unit provide an easily visible indication of the direction the hydraulics valves should be actuated to bring the blade to the set position.

The hydraulics valves can be actuated either automatically or manually, from the panel using keys or a joystick. The DUO2 can drive ON/OFF hydraulic valves along with PV and PI without need of any external accessory.

2. USER INTERFACE

2.1 GRAPHIC DISPLAY

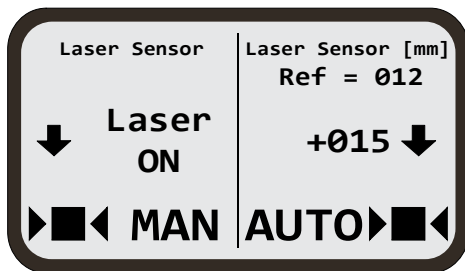

figure 2

The graphic display indicates the panel status, sensor reading and sensor dead band accuracy setting. Menus, parameters, important information and various settings are displayed when menus are accessed.

2.2 KEY FUNCTIONS

Power Key - turns the unit ON/OFF

Enter Key - use to accept settings or change settings while in the menu

Menu Key - use to access the configuration menu

Aux Hyd Up and Down Keys -

to scroll through menu options, to increase or decrease the value of a setting, or to move AUX1 and AUX2 when connected

figure 3

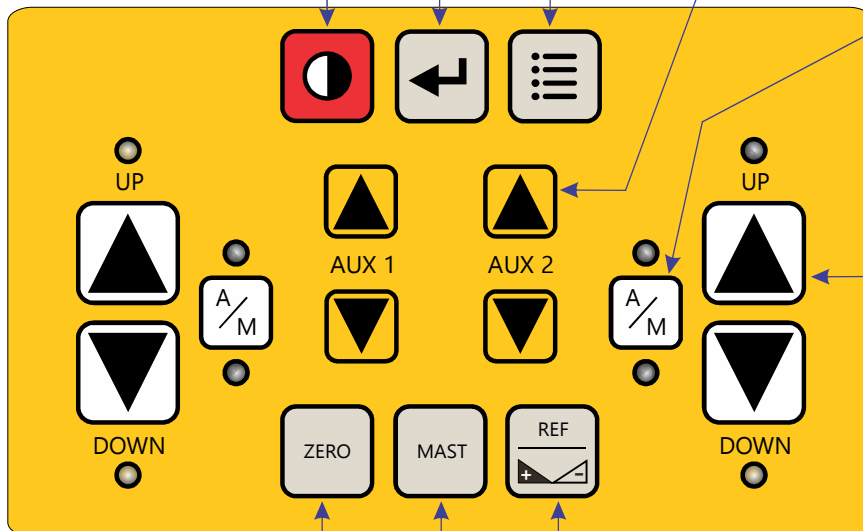

A/M Key - changes the hydraulics valve control between two operating modes: **manual mode** or **automatic mode**

Hyd Up and Down Keys - use to manually move hydraulics in up or down direction

Mast Key - to flip between mast screen and sensor screen

Hydraulics left/right Key - reverses the sign of offset















Grade to Zero Key - set the value of the connected sensor or mast to zero (not available for all sensor types)



2.3 KEY LEGEND:



This manual uses key designator for each graphical key representation. Please refer to this section for graphical key equivalent of each key designator.

CONTROL PANEL

-  = [POWER] key
-  = [MENU] key
-  = [ENTER] key
-  = [ZERO] key
-  = [MAST] key
-  = [REF] key
-  = [A/M] key
-  = [AUX1] key
-  = [AUX2] key
-  = [AUX2] key
-  = [AUX2] key
-  = [UP/DOWN] key
-  = [UP/DOWN] key
-  = [UP/DOWN] key

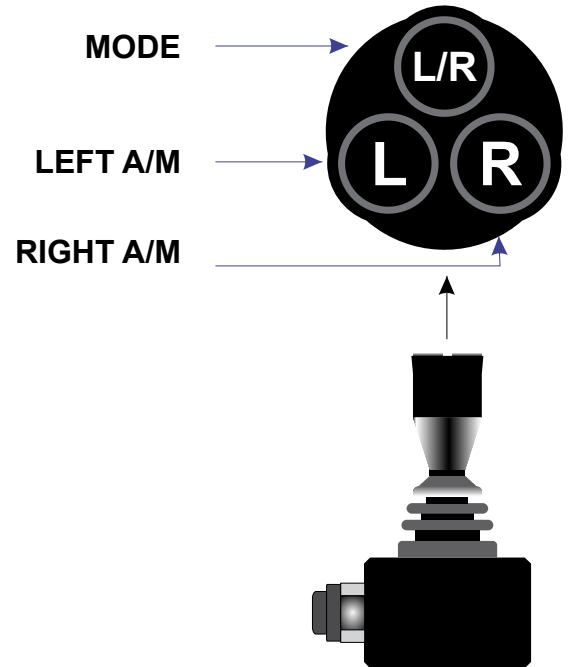
MINI JOYSTICK



-  = [L/R] button
-  = [LEFT A/M] button
-  = [RIGHT A/M] button



2.4 LED INDICATION



AUTO LEDS: ON when hydraulics control for the side is in automatic mode.

MANUAL LEDS: ON when hydraulics control for the side is in manual mode.

UP/DOWN LEDS: ON when hydraulic valve for the side is activated up or down.

2.5 SENSOR LIGHTS

The sensor lights indicate the magnitude of the deviations from the centre or 'ON TARGET' and the required direction of the valve actuation to return to centre or 'ON TARGET'. Meaning of the different sensor light indications:

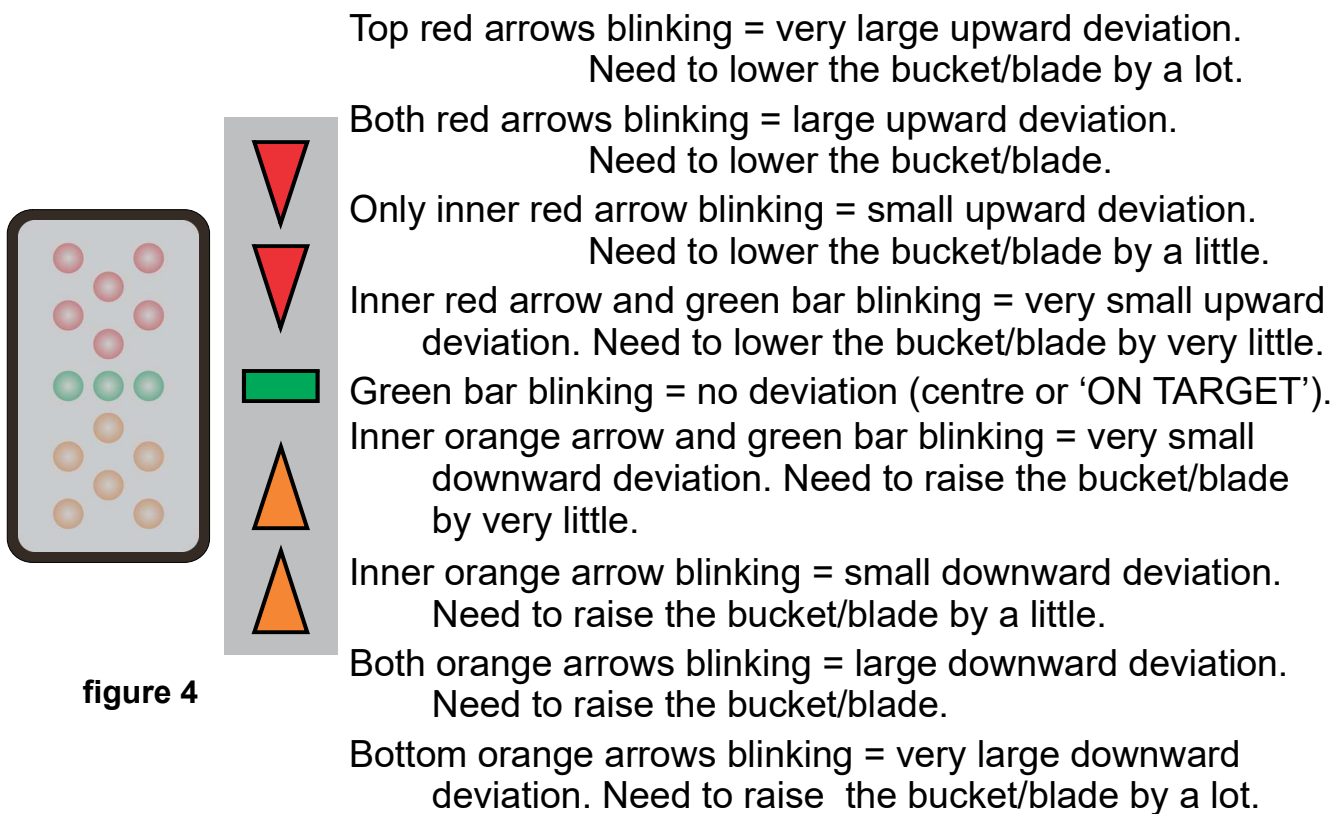

figure 4

Memory mode: If only top red or bottom orange arrows are blinking at slow rate it indicates the last direction of required correction before the laser beam went off the sensor receiving area.

No communication: If both top red and bottom orange arrows blink together it indicates that the panel has lost communication with the sensor. Please check the cable connection at this point.



LOW BATTERY WARNING

If the battery voltage drops below the level required to operate the unit, a low battery symbol will appear on the LCD briefly before the unit automatically shuts down.

figure 5

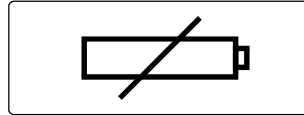

2.6 CONFIGURATION MENU

A variety of settings and features can be set or adjusted through the DUO2 configuration menu.

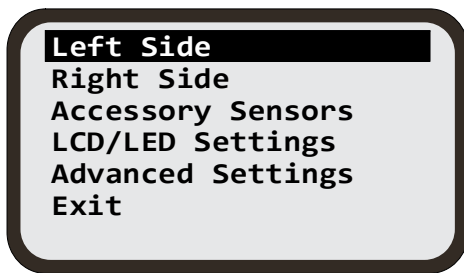

figure 6

Settings include simple things like brightness of the panel LEDs to more advance settings like configuration of different hydraulic valve types.

From the working screen press the [MENU] key to bring the configuration main menu screen.

As discussed before the left side and right side submenu give access to settings related to hydraulics and sensor.

Using [AUX2] key, scroll down to select the side and then press the [ENTER] key. To bring the hydraulics and sensor setting menu for right side, follow the steps below.

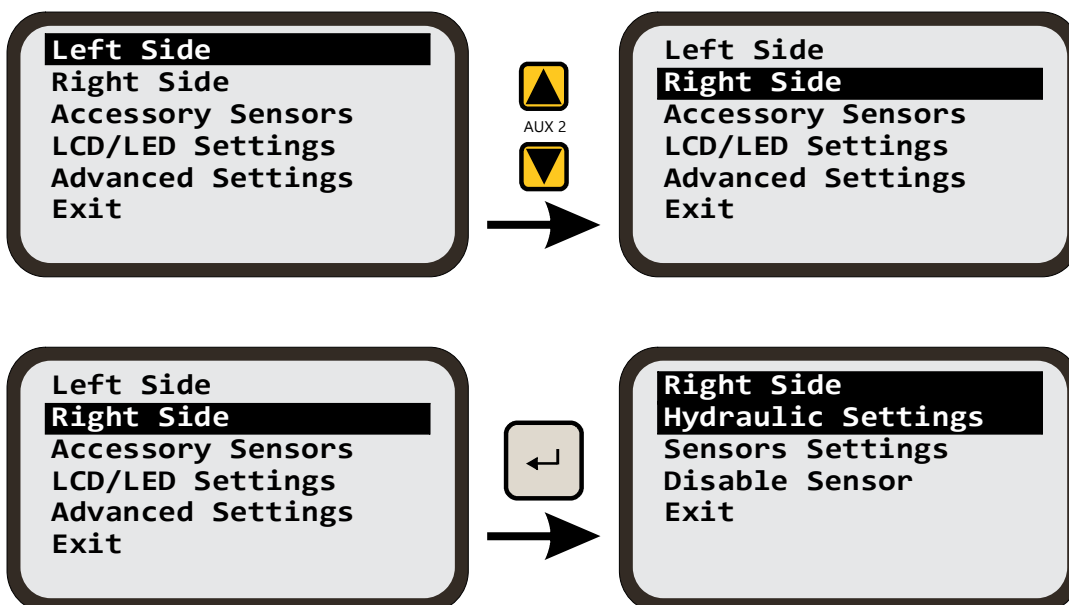

figure 7



3. FIRST STEPS

This chapter will provide you with information in connecting and setting up DUO2. In addition, a description of the symbols and displays used in the working window will be explained.

3.1 BASIC SETUP

The DUO2 control panel can be setup in multiple different configurations as illustrated below.

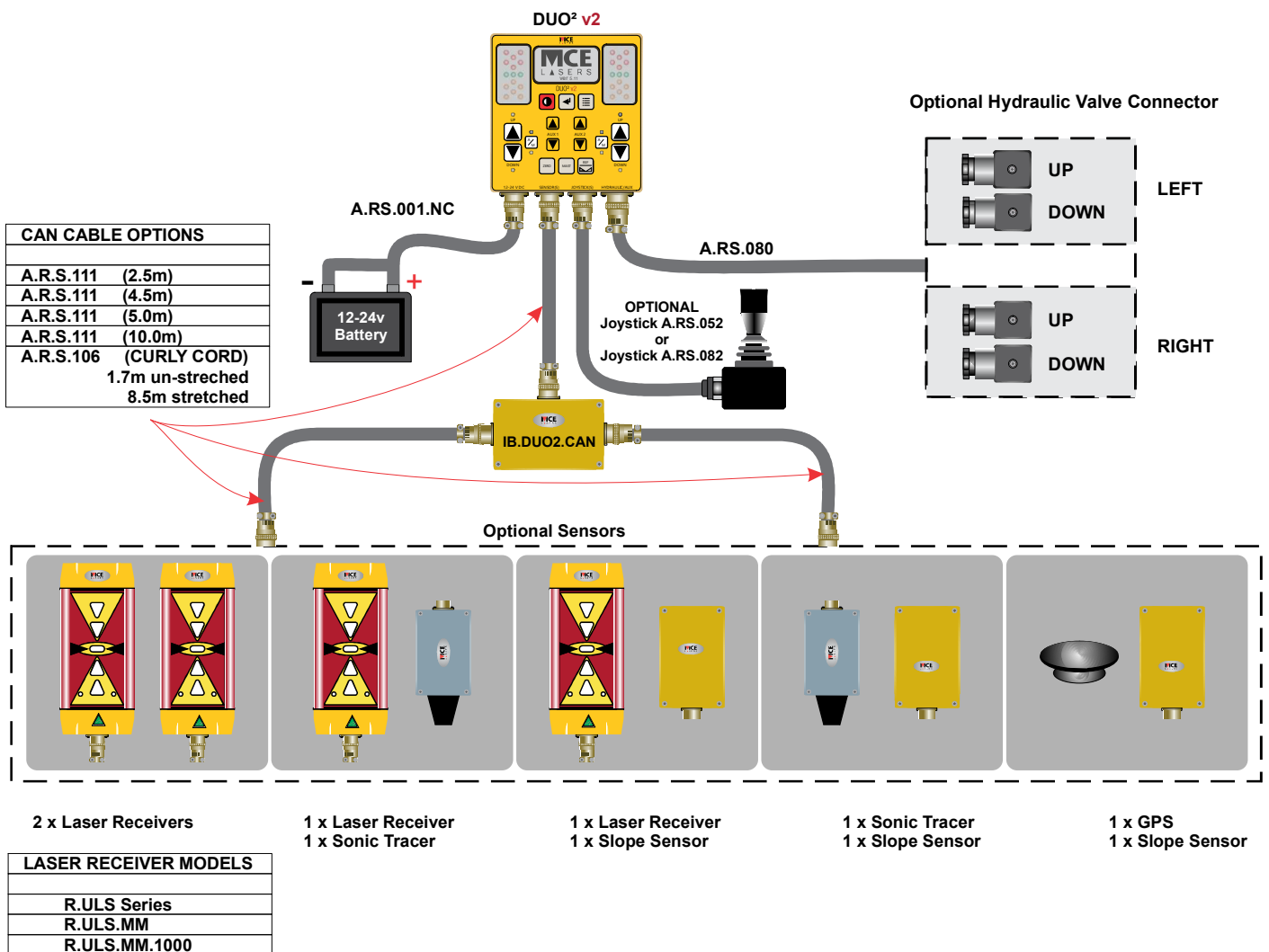

figure 8



3.2 CABLE CONNECTIONS

	Option 1 (RS232 Comm)	Option 2 (CAN Comm)
Connection	Cable Number	Cable Number
DUO2 - Power	A.R.S.001 or A.R.S.001.NC	A.R.S.001 or A.R.S.001.NC
DUO2 - IB.DUO2 (junction box)	A.R.S.094	Straight CAN Cord Options
IB.DUO2 - sensor (left side)	A.R.S.074 or A.R.S.034	Straight and Curly CAN Cord Options
IB.DUO2 - sensor (right side)	A.R.S.074 or A.R.S.034	Straight and Curly CAN Cord Options
DUO2 - hydraulic valves	A.R.S.080	A.R.S.080
DUO2 - joystick/remote	No cable required, connect joystick directly	No cable required, connect joystick directly

table 1

3.3 CONNECTING THE DUO2

- 1) Mount the DUO2 panel somewhere easily accessible by the operator and secure it properly.
- 2) Mount the IB.DUO2 or IB.DUO2.CAN (Junction Box) and connect it to the connector labelled SENSOR(S) on the DUO2 using appropriate cable listed in the table above.
- 3) Mount both sensors on posts or brackets mounted on the blade or bucket and connect them to the junction box using appropriate cable listed in the table above.
- 4) Connect the joystick (optional) to the JOYSTICK connector on the DUO2.
- 5) Connect 12-24v DC (machine battery) to the connector labelled 12-24 V DC on DUO2 using appropriate cable listed in the table above.
- 6) Connect the hydraulic valves to the connector labelled 'Hydraulics' on the DUO2 using A.R.S.080 cable. The end of the cable with the bare wires should be connected to the valves as explained in the following section. Note that the hydraulic valves are normally part of the machine and are not supplied by the MOBA Australia.



3.4 HYDRAULIC VALVES CONFIGURATION

The CB.D2.CAN can manually and automatically drive most of the commercially available solenoid valves, including popular brands such as Danfoss, Eaton-Vickers, Rexroth and others. It has four different types of hydraulic output drive signal available, suitable for different types of valves as explained in the table below.

Hydraulic Output Type	Output Drive	Example Solenoid Valves That Can Be Driven	Menu Selection	Description
Voltage Proportional	Voltage Signal	Danfoss PVG series with PVE actuator	V[0]	This output is a low current voltage signal, not intended to drive a solenoid directly. Mainly used with Danfoss Proportional Valves which have the PVE actuator incorporated, but other valves with similar actuator can also be driven. Valve spool stroke is proportional to the voltage signal.
Current Proportional	Current	1) Eaton-Vickers KDG4V series 2) Rexroth 4WRAB6	I[0]	This current output can be up to 3A and can directly drive a solenoid. Valve spool stroke is proportional to the current amplitude.
ON/OFF Low Side	Current	1) Eaton-Vickers KDG4V series 2) Rexroth 4WRAB6	ON/OFF (Low Side)	This current output can be up to 3A and can directly drive a solenoid. The 'Low Side' refers to the activation method which is done by switching ground. Valve spool stroke is either maximum (solenoid active) or neutral (solenoid inactive).
ON/OFF High Side	Current	1) Danfoss ON/OFF with PVEO actuator 2) Eaton-Vickers KDG4V series 3) Rexroth 4WRAB6	ON/OFF (High Side)	This current output can be up to 3A and can directly drive a solenoid. The 'High Side' refers to the activation method which is done by switching the positive voltage supply. Valve spool stroke is either maximum (solenoid active) or neutral (solenoid inactive).

Table 1: Hydraulic Output Types



The CB.D2.CAN is normally supplied with hydraulic cable A.RS.080 which has colour-coded and labelled bare wires on one end allowing the user to connect their valve according to the particular hydraulic output type requirement for that valve.

Below are examples of how to connect the bare wires for each of the four hydraulic output types using as examples some common valve brands and assuming Hirschmann type connector (CETOP valves). The table can be used as a guide for connecting other valve brands and models, once their hydraulic output requirement and pinout is known.



Hydraulic Output Type	Example Valves	Valve Pin Layout*	Connections of A.RS.080 Bare Wires (Wire Colour - Wire Label)
Voltage Proportional (V[O])	Danfoss PVG series with PVE actuator		PIN 1: Grey – VCC PIN 2: Yellow – SIG1/UP1 PIN 3: Not Connected GND: Pink - GND
Current Proportional (I[O]) or On/Off Low Side	1) Eaton-Vickers KDG4V series (Current Proportional output) 2) Rexroth 4WE6 (On/Off Low Side output) 3) Eaton-Vickers DG4V series (On/Off Low Side output). <i>Note: The Rexroth 4WE6 and Eaton-Vickers DG4V can also be driven with On/Off High Side output if wired as shown in On/Off High Side below</i>	Up Coil 	PIN 1: Grey – VCC PIN 2: Yellow – SIG1/UP1 GND: Pink - GND(Optional)
		Down Coil 	PIN 1: Green – VCC PIN 2: Orange – DOWN1 GND: Not Connected
On/Off High Side	1) Danfoss On/Off with PVEO actuator 2) Rexroth 4WE6 series 3) Eaton - Vickers DG4V series <i>Note: The Rexroth 4WE6 and Eaton - Vickers DG4V can also be driven with On/Off Low Side output if wired as shown in On/Off Side row above.</i>		PIN 1: Orange – DOWN1 PIN 2: Yellow – SIG1/UP1 PIN 3: Not Connected GND – Pink - GND
		Up Coil 	PIN 1: Pink – GND PIN 2: Yellow – SIG1/UP1 GND - Pink-GND(Optional)
		Down Coil 	PIN 1: Pink – GND PIN 2: Orange – DOWN1 GND: Not Connected

Table 2: Typical Hydraulic Cable Connections

* In cases where valve pins are not numbered, use the position of the straight pin relative to the other pins as shown in the pin layout to determine which pin is which.



The CB.D2.CAN can optionally drive an additional On/Off type valve which can be used for auxiliary functions such as, for example, moving a wheel up and down on a skid steer machine. This hydraulic output can normally only be activated manually using the Aux Up and Down buttons. In special cases, when selected through the Advanced Settings in the menu, the Aux Up can be activated automatically whenever the main hydraulic output (up or down) is activated.

Below is how to connect this valve using the bare wires of the A.RS.080 cable, assuming CETOP type valve (Hirschmann connector).

Valve Pin Layout	Connections of A.RS.080 Bare Wires (Wire colour- Wire Label)
Up Coil 	PIN 1: White - AUX1/ UP PIN 2: Pink – GND PIN 3: Not Connected
Down Coil 	PIN 1: Black - AUX1/DOWN PIN 2: Pink – GND PIN 3: Not Connected

Table 3: Typical Auxiliary Hydraulic Connections



3.5 POWERING UP

Before powering up the DUO2 for the first time, a visual inspection is recommended to confirm everything is connected correctly and is well secured (refer top sections 3.1 - 3.4).

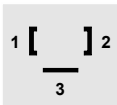
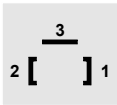
Check and confirm especially that the type of hydraulic valves has been correctly determined and the wiring has been done as per section 3.4 for the particular type of valves. Check all system components for obvious damage, all cable connections for securely fitted connections and the sensor for secure and accurate mounting. When starting up the DUO2 ensure that no person or objects are located within range of the moving parts of the machine.

Press and hold the [POWER] key for 3 seconds to turn the unit on.

The DUO2 system will go through initialisation sequence and the working screen will come up.

3.6 WORKING SCREEN

The working screen is divided into left and right side control. Information and settings related to individual side show separately on left or right side of the screen. See the typical example of working screen when laser beam is hitting the sensors and system is connected with one P sensor on the left side and one mm sensor on the right side.

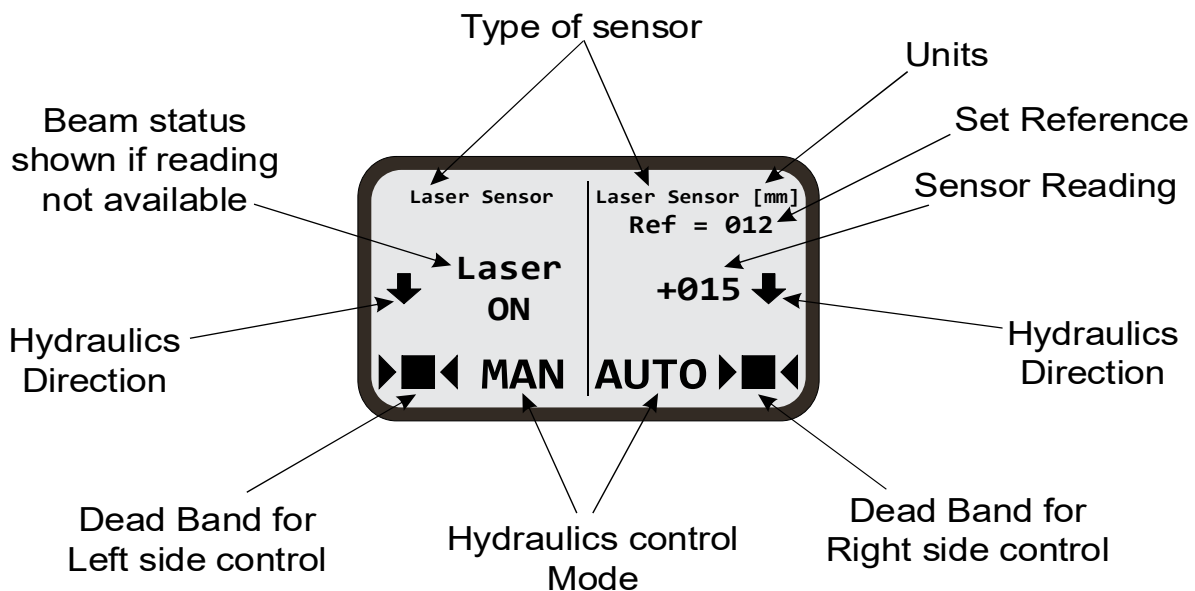
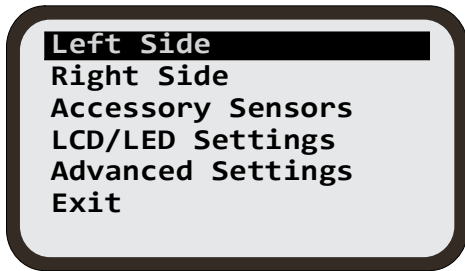

figure 9



3.7 SETTING UP THE HYDRAULICS



As the DUO2 supports multiple types of hydraulic valves, it is very important to firstly select the correct type of valve operating on the machine.

From the Working screen press the [MENU] key to bring up the configuration menu Main screen.

figure 10

The settings for hydraulics are classified separately for left side and right side. Individually adjust the settings for left side control and right side control by going into submenu option “Left Side” or “Right Side”.

Using [AUX2] key select the side and then press [ENTER] key.

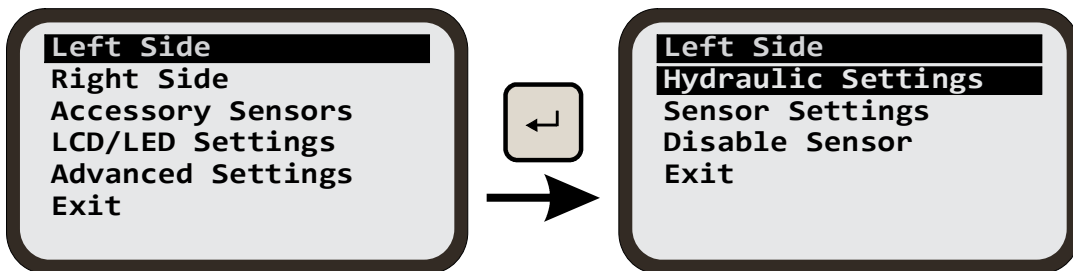

With Hydraulics Settings highlighted press the [ENTER] key to access Hydraulics settings submenu.

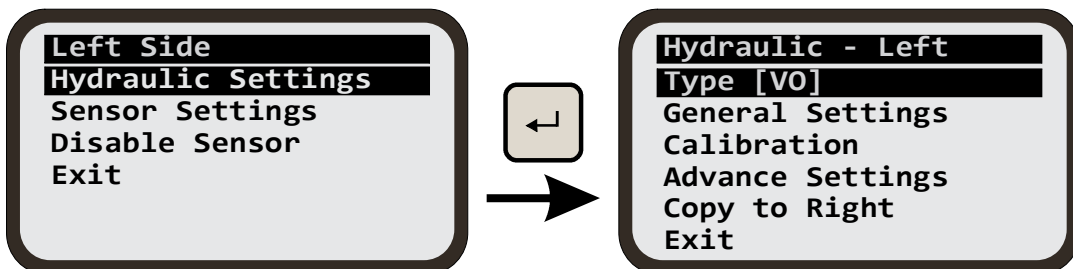

figure 11



3.7.1 SELECTING TYPE OF HYDRAULICS

The currently selected hydraulics type is shown in []. Press the [ENTER] key to access hydraulics type selection submenu.

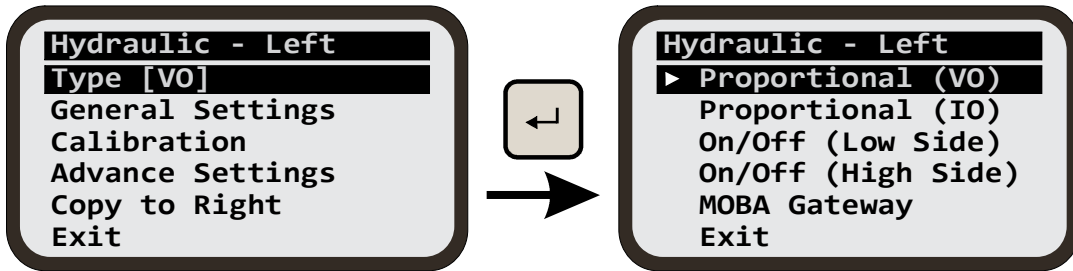
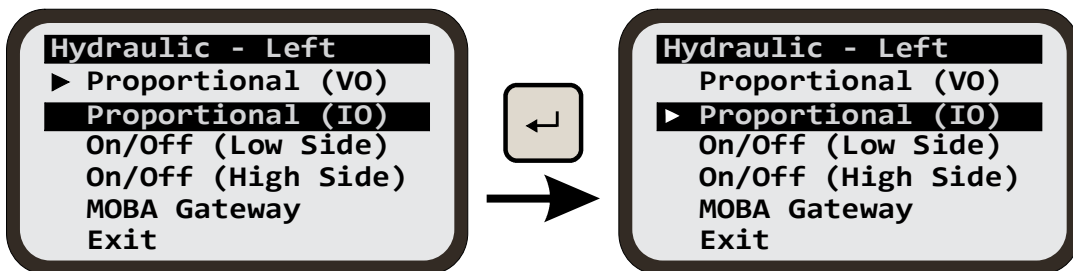

figure 12

The DUO2 supports the following commercially available hydraulics valve types.

1. Proportional (VO) - Voltage controlled proportional hydraulics
2. Proportional (IO) - Current controlled proportional hydraulics
3. On/Off - Bang-Bang type. The DUO2 provides flexibility to activate on/off type valves via a low drive signal, option On/Off (low side), or via a high drive signal, option On/Off (high side).

Using [AUX2] key select the type of Hydraulics connected on the machine and then press [ENTER] key to set.



When finished, use [AUX2] key to select Exit and press [ENTER].

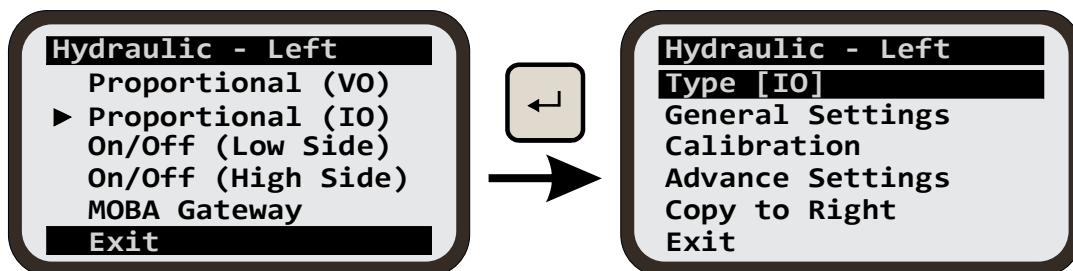

figure 13



3.7.2 ADJUSTING THE SETTINGS FOR HYDRAULICS RESPONSE

Using [AUX2] key select 'General Settings' for hydraulics then press the [ENTER] key.

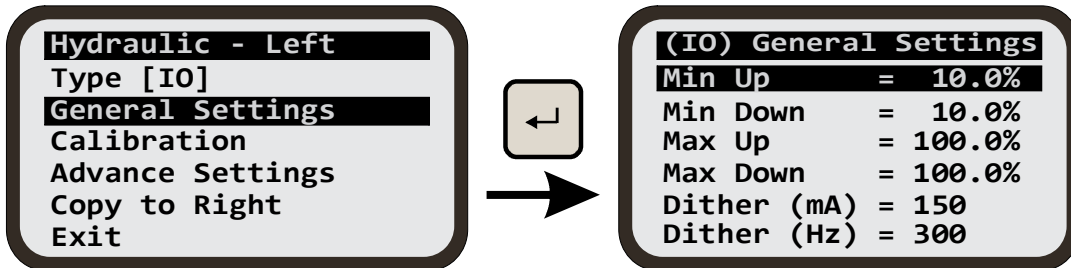

figure 14

Different hydraulics types have different hydraulics settings which controls the behaviour of the hydraulics response during auto mode of operation. Select the hydraulics type as described in the previous section and then adjust the settings under 'General Settings' to optimise the hydraulic response .

To adjust these settings:

1. Use [AUX2] key to select a setting and then press the [ENTER] key.
2. The setting will start to blink indicating that the unit is in editing mode. Use [AUX2] key to adjust the value .
3. When finished adjusting, press [ENTER] key again to exit editing mode.
4. To exit the submenu, use [AUX2] key to select exit then press [ENTER].

The overall hydraulic response depends on many factors that differ from user to user. These include hydraulic oil pressure, size of the blade or bucket being moved, valve brand, sensor connected to the DUO2 and others. Because of this, there is not one set of correct settings to use. The following sections give an explanation of each of the settings to help the user optimise the overall hydraulic response.



3.7.2.1 GENERAL SETTINGS - VO HYDRAULICS

(VO) General Settings	
Min Up	= 10.0%
Min Down	= 10.0%
Max Up	= 100.0%
Max Down	= 100.0%
Direction	= Normal
Exit	

figure 15

1. Min up: Minimum signal that is applied to move the blade or bucket in upward direction. This signal is applied when the signal from the connected sensor is just on the 'ON TARGET' (green) band. If set too high, the bucket or blade will overshoots the target going up. If set too low, the blade or bucket may not move up at all when only small upward adjustment is required.

2. Min Down: Minimum signal applied to move hydraulics in downward direction. This signal is applied when the signal from the connected sensor is just on the 'ON TARGET' (green) band. If set too high, the bucket or blade will overshoot the target going down. If set too low, the blade or bucket may not move up at all when only small downward adjustment is required.

3. MAX UP: Maximum signal that is applied to move hydraulics in upward direction. This signal is applied when the signal from the connected sensor is below the 'ON TARGET' (green) band by an amount that is greater than or equal to the proportional range of the sensor. If set too high, the bucket or blade may move too fast and overshoots the target. If set too low, movement may be too slow.

4. MAX Down: Maximum signal that is applied to move hydraulics in downward direction. This signal is applied when the signal from the connected sensor is below the 'ON TARGET' (green) band by an amount that is greater than or equal to the proportional range of the sensor. If set too high, the bucket or blade may move too fast and overshoots the target. If set too low, movement may be too slow.

5. Direction: Normal or Reverse direction for hydraulics movement. When Reverse direction is selected, the DUO2 will activate Down hydraulics when up control is applied and will activate UP hydraulics when down signal is applied.



3.7.2.2 GENERAL SETTINGS - IO HYDRAULICS

(IO) General Settings	
Min Up	= 10.0%
Min Down	= 10.0%
Max Up	= 100.0%
Max Down	= 100.0%
Dither (mA)	= 150
Dither (Hz)	= 300

figure 16

1. Min up: Minimum signal that is applied to move the blade or bucket in upward direction. This signal is applied when the signal from the connected sensor is just on the 'ON TARGET' (green) band. If set too high, the bucket or blade will overshoots the target going up. If set too low, the blade or bucket may not move up at all when only small upward adjustment is required.

2. Min Down: Minimum signal applied to move hydraulics in downward direction. This signal is applied when the signal from the connected sensor is just on the 'ON TARGET' (green) band. If set too high, the bucket or blade will overshoot the target going down. If set too low, the blade or bucket may not move up at all when only small downward adjustment is required.

3. MAX UP: Maximum signal that is applied to move hydraulics in upward direction. This signal is applied when the signal from the connected sensor is below the 'ON TARGET' (green) band by an amount that is greater than or equal to the proportional range of the sensor. If set too high, the bucket or blade may move too fast and overshoots the target. If set too low, movement may be too slow.

4. MAX Down: Maximum signal that is applied to move hydraulics in downward direction. This signal is applied when the signal from the connected sensor is below the 'ON TARGET' (green) band by an amount that is greater than or equal to the proportional range of the sensor. If set too high, the bucket or blade may move too fast and overshoots the target. If set too low, movement may be too slow.

5. Dither (Amp): adjusts the amplitude of the dither. This parameter should be set as per the recommendation given by the manufacturer of the hydraulic valve.

6. Dither (Hz): adjusts the frequency of the dither signal. Dither signal is superimposed with the control current for improvement of the response of the system. This parameter should be set as per the recommendation given by the manufacturer of the hydraulic valve.

7. Direction: Normal or Reverse direction for hydraulics movement. When Reverse direction is selected, the DUO2 will activate Down hydraulics when up control is applied and will activate UP hydraulics when down signal is applied.



3.7.2.3 GENERAL SETTINGS - ON/OFF HYDRAULICS

The On/Off hydraulic output can be made to pulse or to be solid.

On/Off (Low) Settings	
F-Sampling	= 4.0%
Min Pulse Up	= 50ms
Min Pulse Dn	= 50ms
Max Pulse Up	= 250ms
Max Pulse Dn	= 250ms
Max Up	= 100%

figure 17

1. **F-Sampling:** frequency of the pulsing hydraulic signal. A higher number gives more rapid bursts of adjustment. A lower number gives slower bursts of adjustment.
2. **Min Pulse Up:** the duration of the up pulse when the signal from the sensor is just below the 'ON TARGET' (green) band. If set too low, the bucket or blade may not move at all when small adjustment is required. If set too high, the bucket or blade will overshoots the target.
3. **Min Pulse Down:** the duration of the down pulse when the signal from the sensor is just below the 'ON TARGET' (green) band. If set too low, the bucket or blade may not move at all when small adjustment is required. If set too high, the bucket or blade will overshoot the target.
4. **Max Pulse Up:** the duration of the up pulse when the signal from the sensor is below the 'ON TARGET' (green) band by an amount that is greater than or equal to the proportional range of the sensor. If set too high, the bucket or blade may move too fast and overshoots the target. If set too low, movement may be too slow.
5. **Max Pulse Down:** the duration of the up pulse when the signal from the sensor is above the 'ON TARGET' (green) band by an amount that is greater than or equal to the proportional range of the sensor. If set too high, the bucket or blade may move too fast and overshoots the target. If set too low, movement may be too slow.
6. **MAX Up:** Maximum signal current that is applied to move hydraulics in upward direction.
7. **MAX Down:** Maximum signal current that is applied to move hydraulics in downward direction.
8. **Direction:** Normal or Reverse direction for hydraulics movement. When Reverse direction is selected, the DUO2 will activate Down hydraulics when Up control is applied and will activate UP hydraulics when Down control is applied.

If constant (non-pulsing) hydraulic output is required, set Min Pulse Up, Min Pulse Down, Max Pulse Up and Max Pulse Down to be equal with a value of $1/\text{Sampling} \times 1000$. For example, if 'F-Sampling' is set to 4Hz, set all to $1/4 \times 1000 = 250\text{ms}$.



3.7.3 CALIBRATION - HYDRAULICS

The Minimum and Maximum hydraulic signal settings can be determined by selecting the option in the hydraulics menu.

In Hydraulics calibration menu, using [AUX2] key select 'Calibration', then press [ENTER].

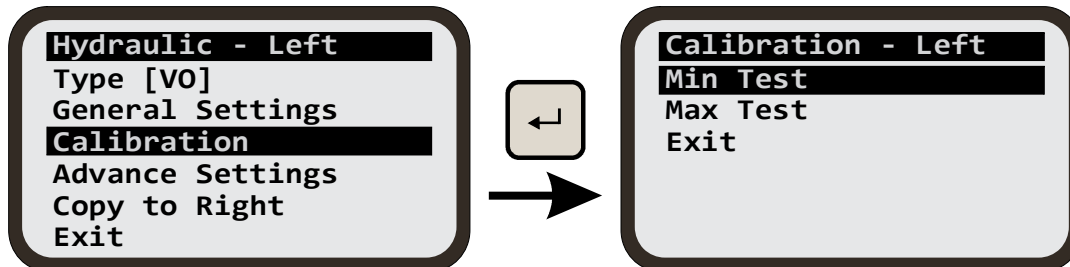

figure 18

The following sections are description of the calibration procedure for the left side. A similar procedure should be followed for the right side.

3.7.3.1 MIN PULSE CALIBRATION (HYDRAULICS)

The minimum settings required to move the blade or bucket up or down can be determined by selecting the 'Min Test' option.

In this test mode the system automatically applies an up and down pulse alternately, allowing the user to see in real time the effect on the blade movement with each change in value for minimum up and minimum down settings.

Press [ENTER] key to begin the Min Pulse calibration.

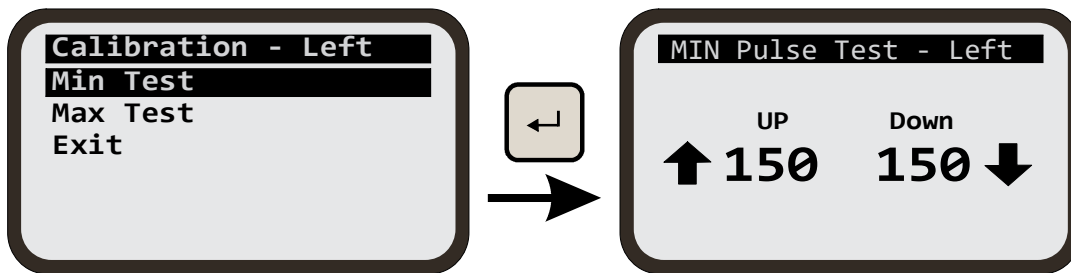

figure 19

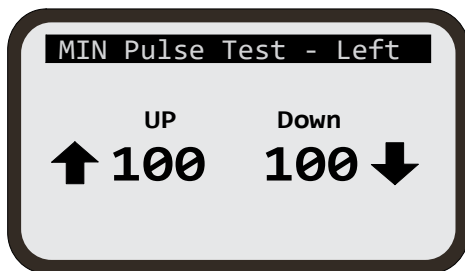

figure 20

When doing Min Pulse Test, the aim is to find the minimum setting which will move the blade or bucket by the smallest amount in both upward and downward direction.

Use the [AUX1] key to adjust the value of Minimum for up.

Use the [AUX2] key to adjust the value of Minimum for down.

To determine the min settings:

1. Manually position the blade or bucket in the middle of the hydraulic cylinder working range.
2. Start with the minimum value of 100 for both up and down
3. Slowly increase the value for Min Up. Stop when a small up movement is noticed on the blade or bucket.
4. Slowly increase the value for min pulse down, stop when a small movement is noticed in blade.
5. Carefully adjust the Min Up and Down around these value to achieve a symmetrical response.
6. When a symmetrical response is achieved, the blade or bucket will oscillate above and below a fixed spot during the test and should not drift gradually up or down.
7. When finished, press the [MENU] key to return back to the Calibration menu.

Note: During the test, the hydraulic cylinder may end up moving to the limit in one direction. Manually move the cylinder back in the middle of its working range before continuing with the test.



3.7.3.2 MAX PULSE CALIBRATION (HYDRAULICS)

The maximum settings required to move the blade or bucket up or down can be determined by selecting the Max test option. In this test mode the system automatically applies an up and down pulse alternately, allowing the user to see in real time the effect on blade or bucket movement with each change in value for maximum up and maximum down settings. When doing calibration for maximum signal, the up and down pulses are spaced by a large time interval than for minimum calibration.

In hydraulics calibration menu, using [AUX1] key, select Max Test and press [ENTER] key to begin the Max Pulse calibration.

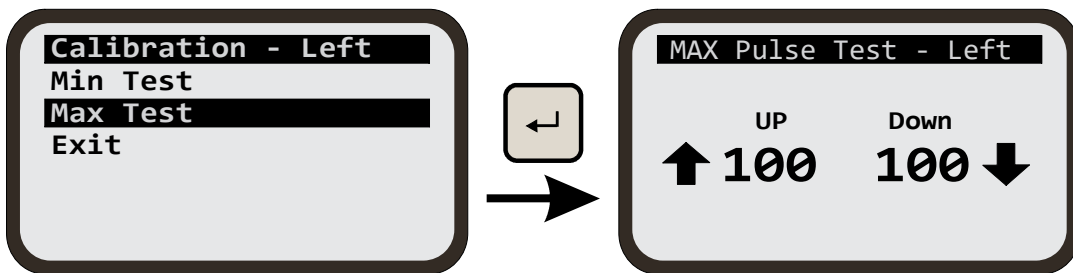

figure 21

When doing the Max Pulse Test the aim is to find a setting which will move the blade or bucket to a satisfactory speed. Adjust the value for up and down to find the smallest acceptable value in both directions.

Use [AUX1] key to adjust the value of Maximum for up.

Use [AUX2] key to adjust the value of Maximum for down.

To determine the optimum Max settings:

1. Manually position the blade or bucket in the middle of the hydraulic cylinder working range.
2. Start with maximum value of 100 for both up and down.
3. Slowly decrease the value for Max Up to find the minimum value giving satisfactory speed.
4. Slowly decrease the value for Max Down to achieve a symmetrical response.
5. When finished, press [ENTER] key to return back to the Calibration menu and then the press [MENU] key to return to the working screen.

Note: During the test the hydraulic cylinder may end up moving to the limit in one direction. Manually move the cylinder back in the middle of its working range before continuing with the test.

Usually more fine tuning of the Max and Min settings may be required after using Auto mode for the first time and observing dynamic behaviour in real working conditions. This can be done by adjusting the Min and Max settings through the menu without entering 'Calibration' mode.



3.7.4 ADVANCED SETTINGS (HYDRAULICS)

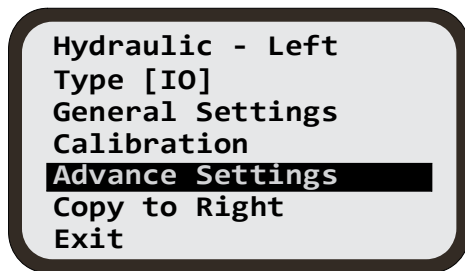

figure 22

The 'Advanced Settings' for hydraulics can be used in special cases where hydraulic response remains unsatisfactory after careful adjustment of the General hydraulic settings. Currently these settings are only available to MOBA Australia service technicians and distributors.

4. WORKING WITH PANEL

Please refer to section 2.2 for Key Functions and Key Designators.

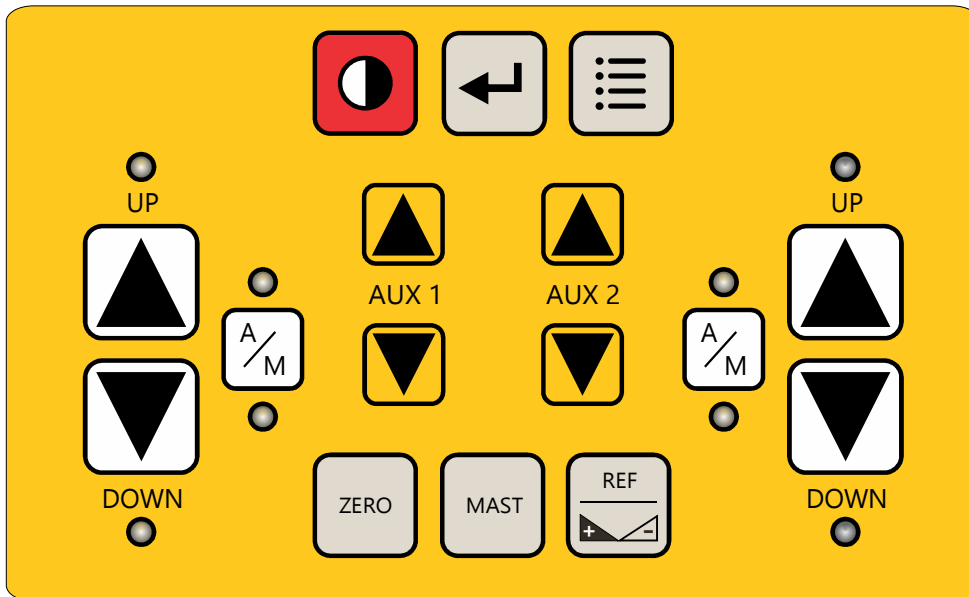

figure 23

4.1 MANUALLY MOVING THE BLADE



From the panel the left side up key can be used to manually activate the valves to move the left side of the blade up.



Similarly the left side down key can be used to manually activate the valves to move the left side of the blade down.



From the panel the right side up key can be used to manually activate the valves to move the right side of the blade up.



Similarly the right side down key can be used to manually activate the valves to move the right side of the blade down.



4.2 SETTING VALVE CONTROL MODE

From the panel use the [A/M] key to switch between the two modes of control for the hydraulics valves.

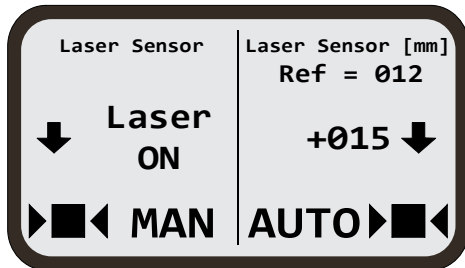

figure 24

MANUAL MODE

When the unit is in manual mode the panel LED MAN will be ON and the MAN will appear on the screen, as shown in the picture below for left side.

When unit is in this mode, blade movement is only controlled by the user. By pressing the [UP/DOWN] key or by using the joystick.

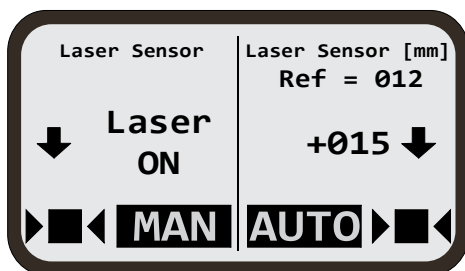

figure 25

AUTO MODE

When unit is in automatic mode, the panel LED AUTO will be on and AUTO will appear on the screen as shown in the picture for right side.

In this mode, the panel automatically brings the blade to the centre position. The user can temporarily override automatic control at any time by pressing the [UP/DOWN] key or by using the joystick.

Automatic control returns upon release of the buttons or joystick handle.

WARNING: Extreme care should be exercised when switching the DUO2 to Auto for the first time in an unfamiliar setup. The mounting of the sensors might be such that, in attempting to achieve center, the blade forcefully digs into the ground; or the default hydraulic settings might cause the blade to oscillate and/or considerably overshoot the center position. The user should be on guard to immediately switch to Manual hydraulic control or switch the unit off.



4.3 GRADE TO ZERO OPERATION

The current screen reading for certain models of laser sensor, for GPS sensor and for masts can be zeroed at any time.

From the working screen press the [ZERO] key to bring up the side selection screen for zeroing.

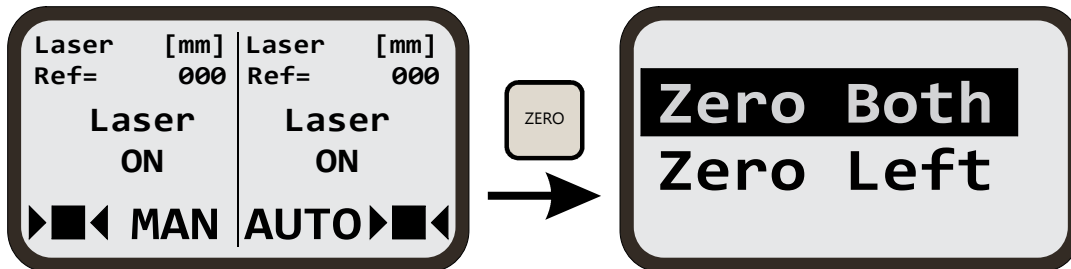

figure 26

Use [AUX2] key to select the side/sensor for which grade is to be set to zero then press [ENTER] key.

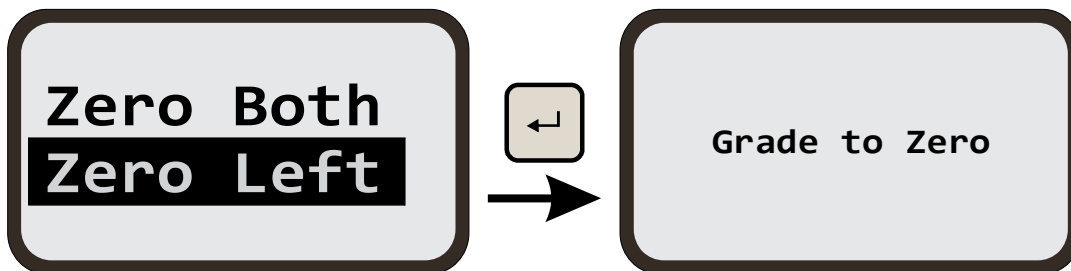

figure 27

The current sensor value for that side will become zero.

Note:

1. Some sensor models do not support grade zero.
2. Grade to zero for laser sensors only works if beam is hitting the sensor.



4.4 REFERENCE, OFFSET & SET TARGET

During normal operation, the currently used reference/set target value is displayed in the second line of the screen for all sensor types.

This value is the desired offset of the blade or bucket from zero position.

Laser sensors allow one reference /offset value only. Slope and tracer sensors both allow up to four reference/offset values. These values are adjustable through the reference menu. At any given time, only one of the four references/offsets can be selected as the current reference/offset for the sensor. From the working screen press and hold the [REF] key to bring up the reference/offset side selection screen.

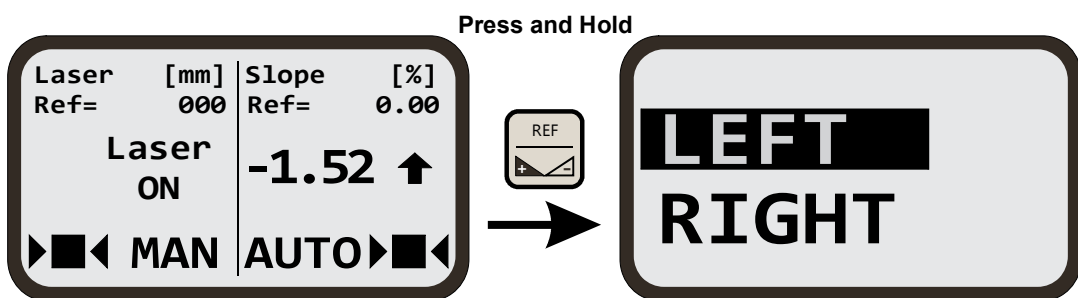

figure 28

Use the [AUX2] key to select the side/sensor for which reference/offset is to be set, then press [ENTER] key to bring up the reference menu.

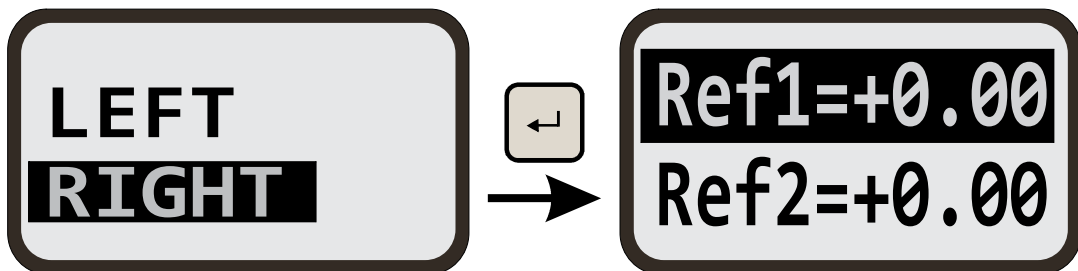
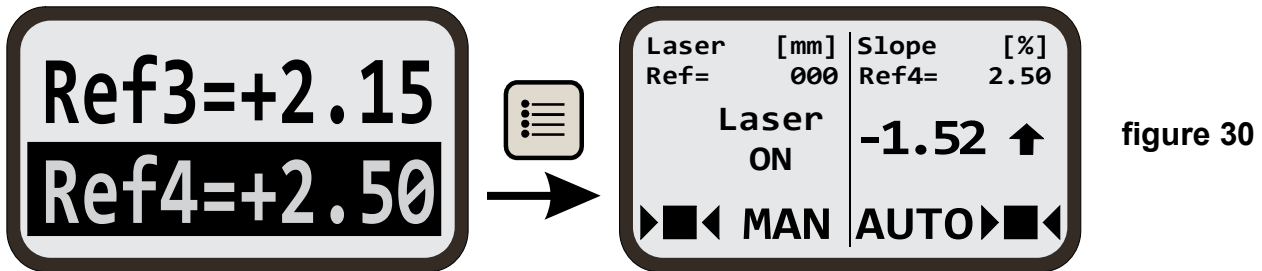

figure 29



4.4.1 TO SELECT THE REFERENCE

From the Ref menu screen, use [AUX2] key to highlight the reference/offset, then press the [MENU] key to select the Reference/offset. The screen will return back to the working screen and the selected Ref will be shown on the second line of the screen.



4.4.2 TO ADJUST REFERENCE/OFFSET

From the Ref menu screen, use [AUX2] key to highlight the reference, then press [ENTER] key.

The value will start to blink. Now use [AUX2] key to adjust the screen value. Press [ENTER] key when finished adjusting

4.4.3 TO TRANSFER CURRENT SENSOR VALUE INTO REFERENCE/OFFSET

From the Ref menu screen, use [AUX2] key to highlight the reference, then press and hold the [ENTER] key until the current value is set into reference.

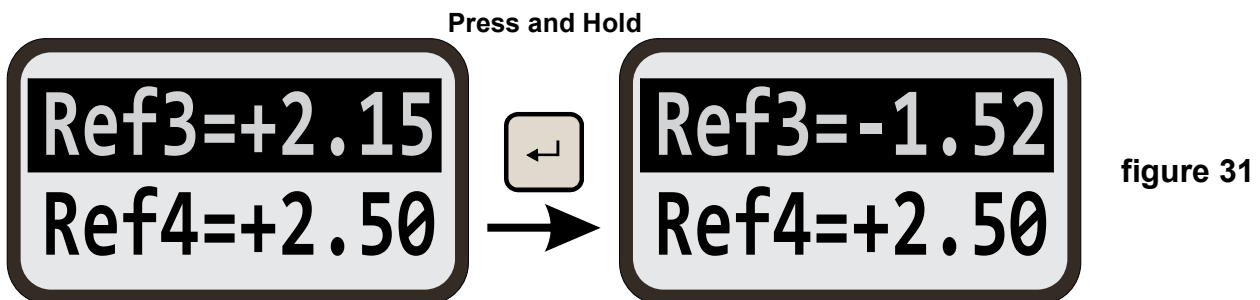

4.4.4 TO ZERO REFERENCE/OFFSET VALUE

Use [AUX2] key to highlight the reference, then press [ENTER] key to edit the Ref value. Press the [AUX2] Up and Down keys together to zero the Ref value.

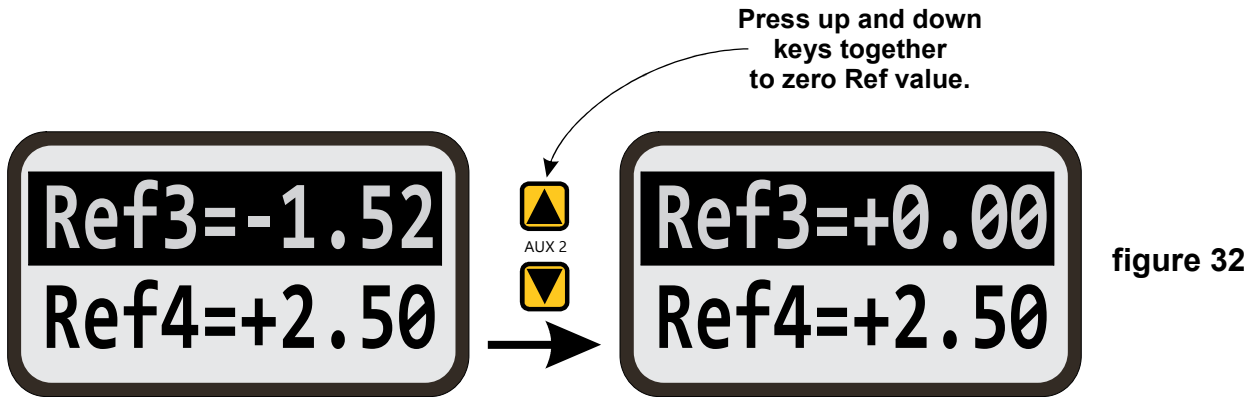

The currently selected Ref can also be adjusted from the Standard Screen without entering Ref menu. Simply press [AUX2] Up or Down key to adjust the value. Proviso is that the function of the Aux keys has been selected through the menu for this purpose..

4.5 HYDRAULICS L/R FOR SLOPE SENSOR

To invert the sign of the current grade offset from positive to negative or vice versa, press the [REF] key. The inverted offset will be highlighted. This feature is intended to allow the operator to continue grading the same slope after doing a U-turn with minimal readjustments. Available only for slope sensors.

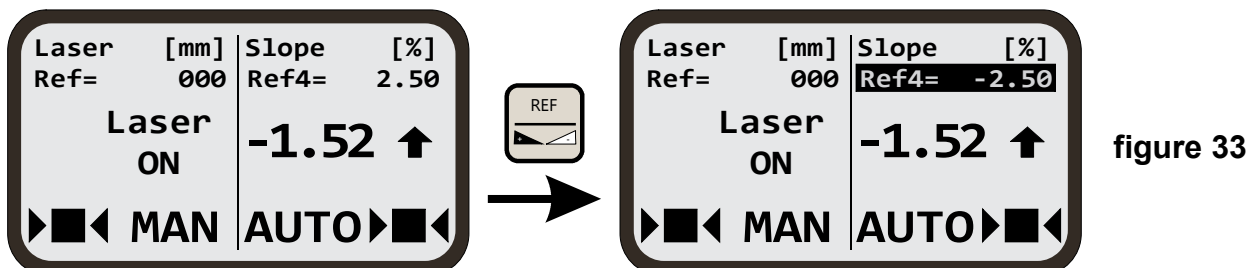

4.6 AUXILIARY CONTROL

In addition to the left and right side hydraulic control, the DUO2 has the ability to control two auxiliary On/Off type valves which can be used for user defined applications such as smudge bar control. These can only be operated manually using [AUX1] and [AUX2] Up/Down keys and while in working screen only. To use these keys for Auxiliary valve activation, this function should be allocated to these keys through the menu. The next section shows how to setup auxiliary keys.

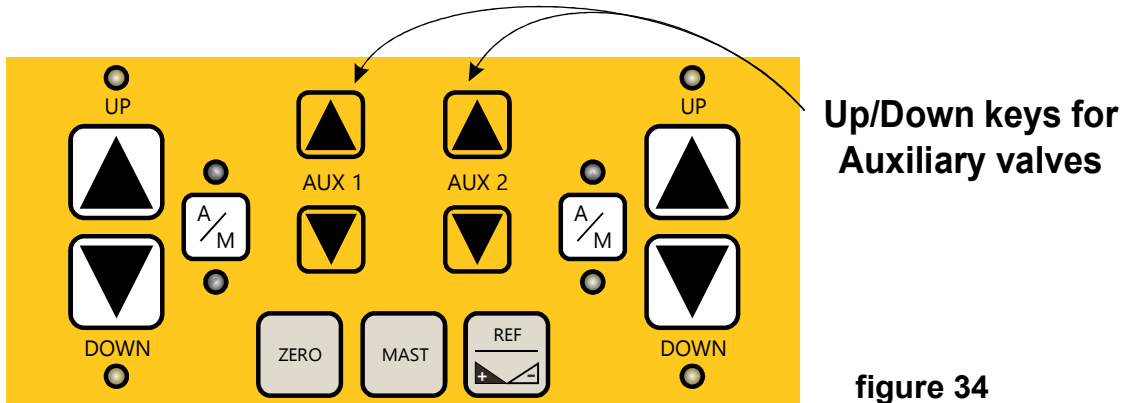

figure 34

4.6.1 AUXILIARY KEYS SETTING

Using [AUX2] key to scroll down to select the Advanced Settings, then press [ENTER] key to bring up the advanced settings.

In the Advanced Settings submenu, use [AUX2] key to scroll down to the Aux Keys option.

Press [ENTER] key to toggle between Auxiliary and Reference.

To exit the submenu, Use [AUX2] key to select Exit and press [ENTER] to exit the submenu.

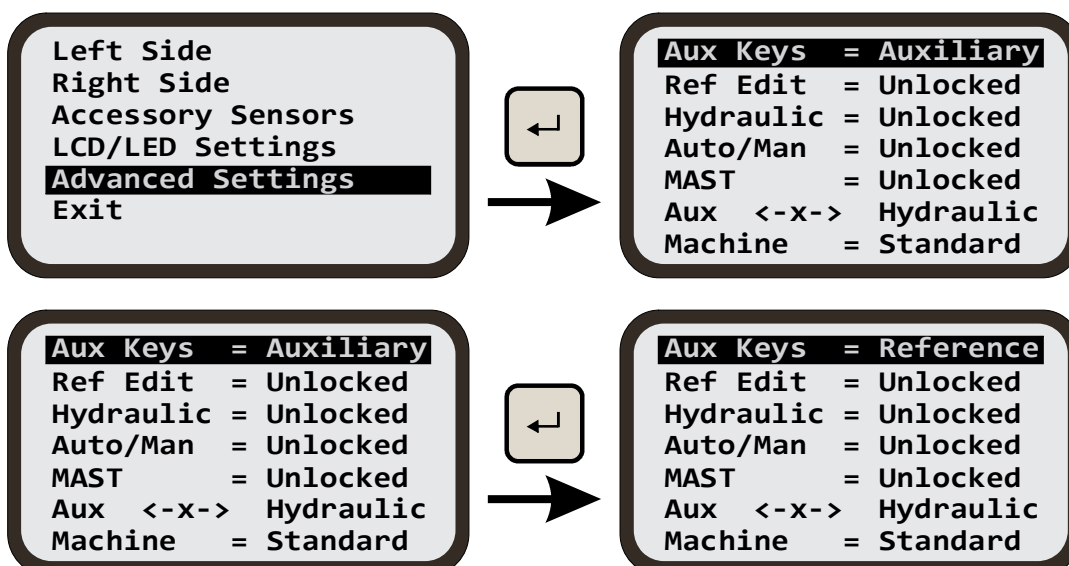

figure 35



5. SENSOR SETTINGS

In either 'Left Side' or 'Right Side' settings menu, using [AUX2] key, scroll down to select the 'Sensor Settings' then press [ENTER] key to bring up the 'Sensor Setting'.

Based on the sensor connected, the settings could differ.

SLOPE SENSOR SETTINGS

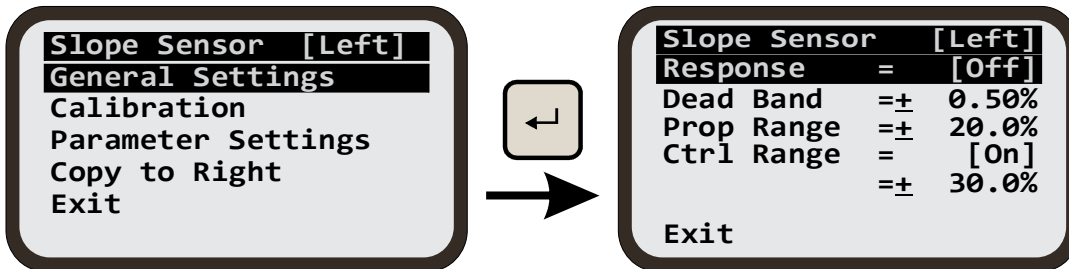

LASER SENSOR SETTINGS

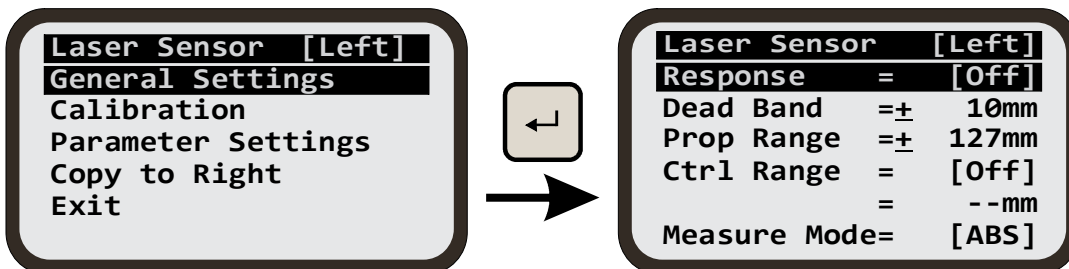

SONIC TRACER SENSOR SETTINGS

figure 36

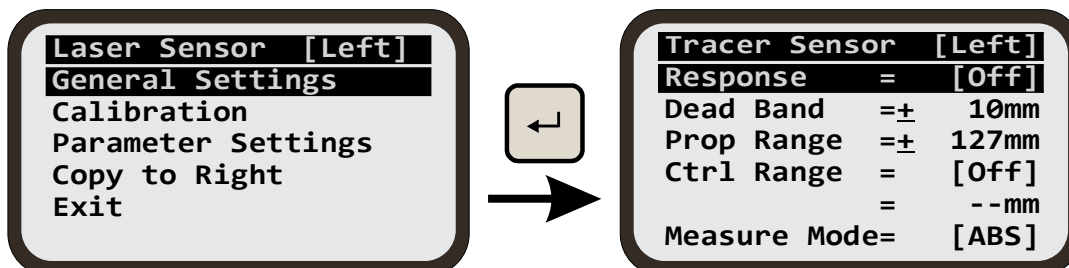

GNSS SENSOR SETTINGS

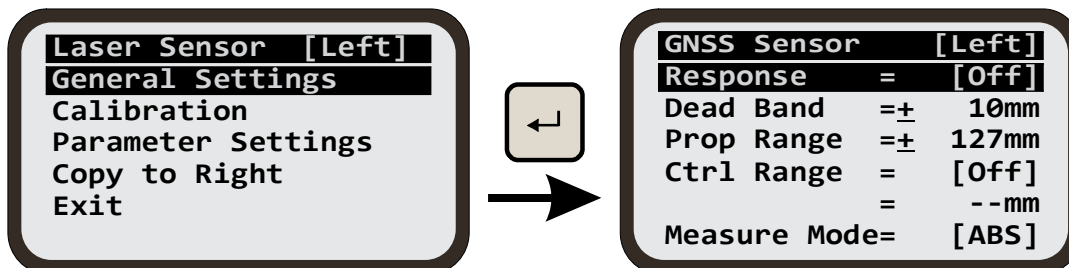

5.1 GENERAL SENSOR SETTINGS

5.1.1 RESPONSE ADJUSTMENT

When enabled, response lets you select between 90 predefined setting combinations of deadband and proportional range which directly affect the overall response of the system.

Response of 1.0 applies the slowest and most accurate response possible

Response of 10.0 applies the fastest and least accurate response possible

Example: SLOPE SENSOR RESPONSE ADJUSTMENT

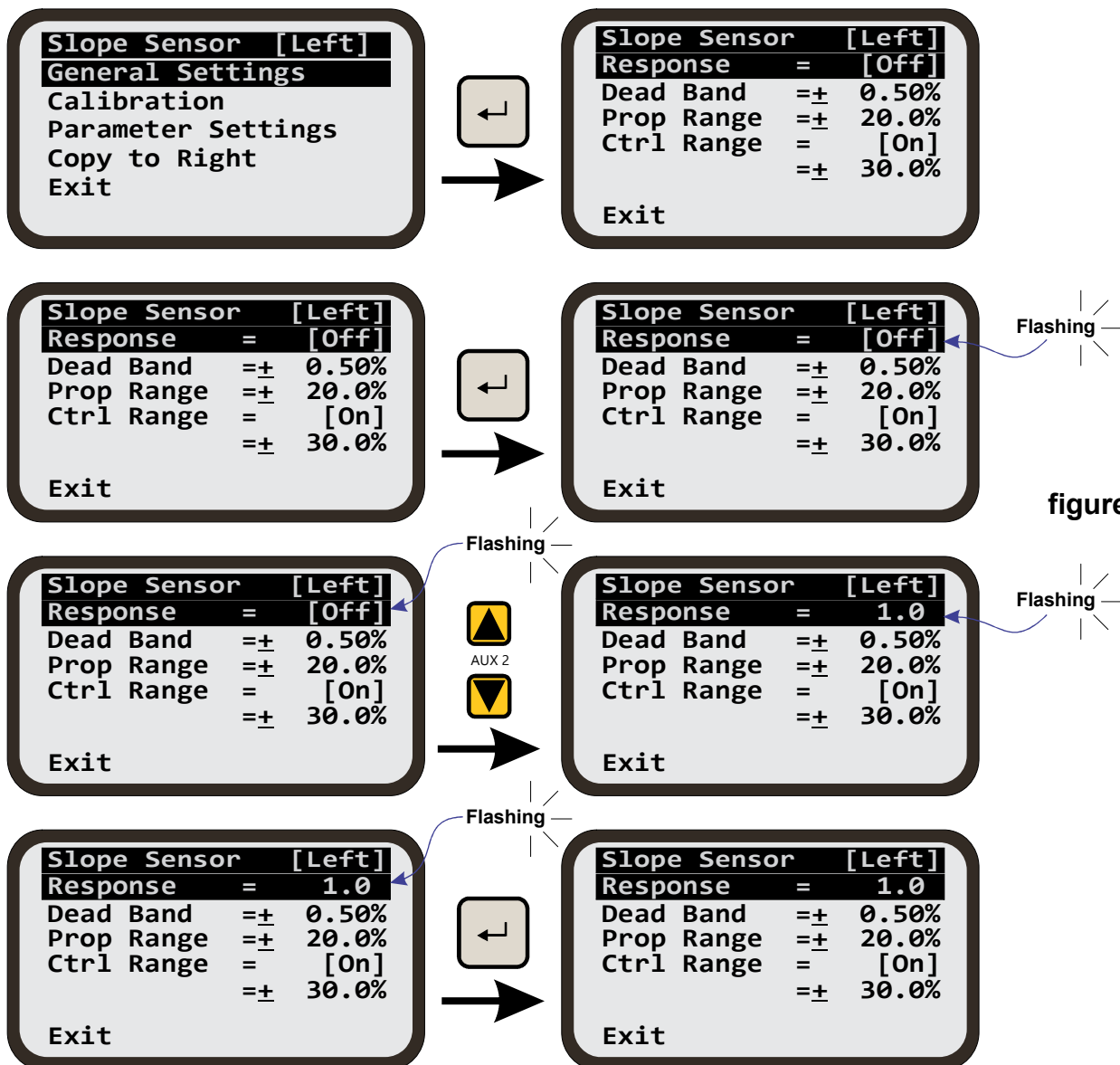

figure 37



5.1.2 DEAD BAND ADJUSTMENTS

This defines the accuracy of the system. The bigger the deadband, the less accurate the system is but the easier it is to achieve fast and stable hydraulic response. Conversely, the smaller the deadband the more accurate the system is but the harder it is to achieve fast and stable hydraulic response. The name deadband derives from the fact that once the sensor reading is within this band around the target (offset), it is considered 'ON TARGET' and stops (Kills off) hydraulic activation until the sensor reading goes outside this band again.

SENSOR TYPE	DEADBAND RANGE
Laser sensor - P	±4 mm; ±20 mm; ±29 mm
Laser sensor - mm	±0.5 mm to ±10 mm
Slope sensor	±0.2% to ±2.8% mm
Sonic tracer sensor	±2 mm to ±10 mm
GPS sensor	

table 3

Note: deadband setting is not available when response is enabled.

From the working screen press [MENU] key to bring up the setting menu. Use [AUX2] key to select the 'Left Side' settings menu.

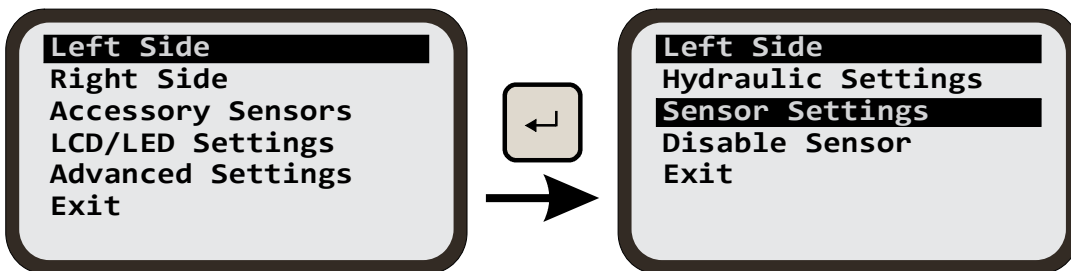

figure 38

Use [AUX2] key to select the 'Sensor Settings' menu and select 'General settings'.

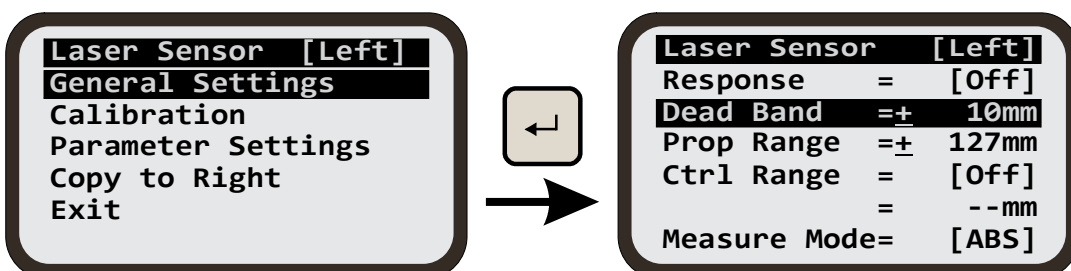

figure 38



5.1.3 PROPORTIONAL RANGE ADJUSTMENT

The Proportional Range is the range of the sensor reading above and below the target over which the hydraulic output signal varies proportionally to the deviation of the sensor reading from the target.

The Min hydraulic output is applied when the sensor reading is just outside the deadband (beginning of the Proportional range) and the Max hydraulic out put is reached when the sensor reading deviates from the Target by by an amount equal to or greater than the selected Proportional range. A smaller Proportional range means a faster hydraulic response.

SENSOR TYPE	SELECTABLE PROPORTIONAL RANGE
Laser Sensor - P	6 mm to 98 mm
Laser Sensor - mm	4 mm to 128 mm
Slope Sensor	3.1% to 30%
Trace Sensor	4 mm to 100 mm
GPS Sensor	

table 4

Note: Proportional Range setting is not available when response is enabled.

5.1.4 CONTROL RANGE ADJUSTMENT

A selectable range above and below the deadband outside of which the automatic control of the valves is switched off .

SENSOR TYPE	SELECTABLE CONTROL RANGE
Laser sensor - P	3 mm to 98 mm
Laser sensor - mm	3 mm to 128 mm
Slope sensor	1% to 60%
Trace sensor	4 mm to 100 mm
GPS sensor	

table 5



5.1.5 MEASUREMENT MODE

The measurement mode for sensors with ability to zero the reading can switch between Relative [REL] and Absolute [ABS]. Relative mode means that the sensor reading is relative to the position where the zeroing occurred. Absolute mode means the sensor reading is taken from the factory default. Zero position for example, for laser sensors this is the physical centre of the receiving area. After executing a 'zeroing' using the zero button, the measure mode automatically becomes relative. To revert back to absolute, access sensor settings menu, select measure mode and press [ENTER]. ABS is then shown in the square brackets.

Note: On power down, the DUO2 retains the previously used measurement mode. It is important before starting a new job to ensure that the correct measurement mode is selected.

5.1.6 OFFSET

When system is used in Relative Mode this reading shows the offset of the relative 'zero' position from absolute position.

5.1.7 UNITS

Select between various units of measurement for different sensor. Different units available for different sensors are:

Slope Sensor :

1. Percentage [%]
2. Degree [°]

Laser and Tracer Sensor :

1. Centimeter [cm]
2. Millimetre [mm]



5.2 CALIBRATING SLOPE & TRACER SENSORS

5.2.1 BEFORE CALIBRATING SLOPE SENSOR

Using the slope sensor for the first time or after remounting, it is important that it is mounted and calibrated correctly. The mounting should be robust enough to guarantee that the sensor will not move while the blade is being used. Preferably the sensor should not be removed once mounted so as to avoid having to repeat the calibration procedure. Ensure the following when mounting:

- 1.) The 'TOP' inscription on the sensor is on top.
- 2.) The long side of the sensor is parallel with the blade
- 3.) The reading on the screen of the sensor grade increases as the side the sensor is mounted on (or connected to) is raised and decreases as the same side is lowered. If not, turn the sensor 180°, ensuring steps 1-2 are still adhered to.
- 4.) The blade is physically level. This can be checked using a spirit level with a leveling sensitivity of +/- 0.01%.
- 5.) The sensor is approximately level with the blade.

Checks should be done before starting a new job to ensure that calibration is maintained. This involves physically leveling the blade using a spirit level with sensitivity +/- 0.01% and confirming that the reading of the sensor grade on the screen is approximately zero. Ensure that absolute measurement mode is selected when this check is done (see section 5.1.5).

5.2.2 BEFORE CALIBRATING TRACER SENSOR

Tracer sensor is factory calibrated when supplied. However, the user is advised to check periodically that calibration is maintained.

To check and calibrate tracer sensor:

- 1.) Place a suitable target 350 mm away from the tip of the sensor, directly in front and ensure that both target and sensor are fixed in position.
- 2.) Use flat ground as the target and fix the sensor 350 mm above flat ground (from sensor tip to ground),
- 3.) Point the sensor tip directly down and ensure that there are no obstructions between sensor tip and target.
- 4.) Ensure that measurement mode is absolute
- 5.) Check that the sensor reading on the screen is approximately 350 mm.



The operating range of the tracer sensor is maximum 450 mm and minimum 250 mm and during normal grading operations, it is recommended that the sensor is at a distance from the tracked surface roughly midway between the maximum and minimum, ie; roughly 330 - 370 mm above the tracked surface. See section '9. Practical Example' for an example.

To execute calibration of the sensor, press [MENU] key from the working menu. Select the side to which the sensor is installed then select 'Sensor Settings'. Follow the configuration steps described below.

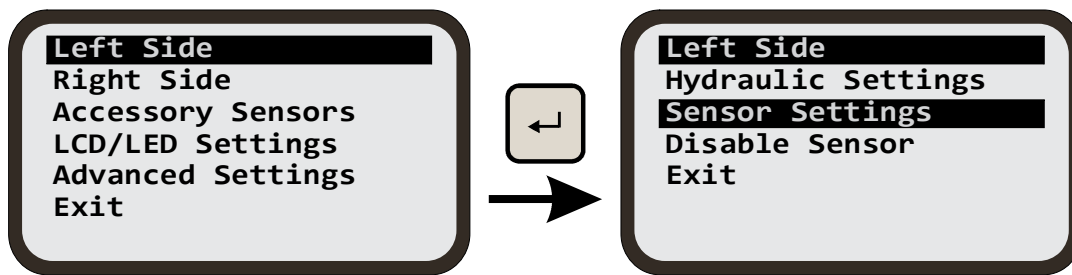
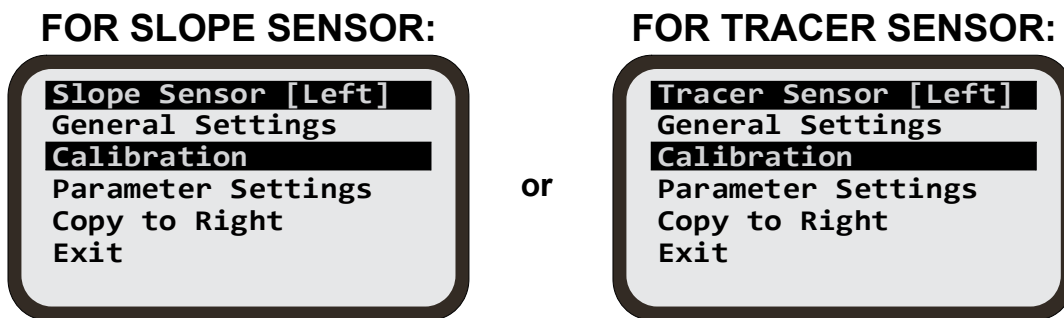
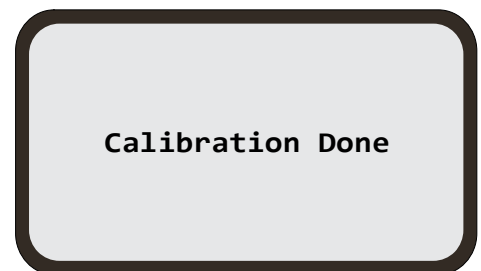
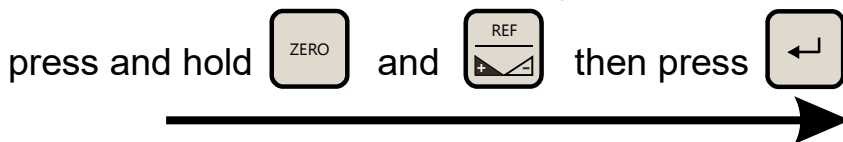

figure 40



To calibrate either of the sensors you need to



If 'Calibration Done' is displayed on the window then the sensor has been successfully calibrated.

Note: On firmware version 5.16, the calibration can also be done by pressing [ENTER] key whilst on the calibration window. The next window will prompt you with "Are you sure you want to do calibration". Simply select [YES] and hit [ENTER] key then "Calibration Done" will be displayed.

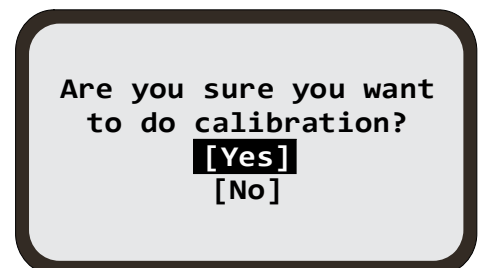



5.3 SLOPE SENSOR - SIDE SELECTION

When one side is controlling the slope of the blade and the other side is controlling the height of the blade, the levelling of the two sides can be done by adjusting one side at the time, rather than both sides at once. By adjusting in turns, the adjustment process is smoother but at the cost of being slower.

To select this method for levelling, go to the main menu and select 'Advanced Settings' option.

In the 'Advanced Settings' menu use [AUX2] key to scroll down to 'Slope Side'. Press [ENTER] key to toggle between 'LEFT', 'RIGHT' and 'NONE'. Use [AUX2] key to select 'Exit' and press [ENTER] key to exit the menu.

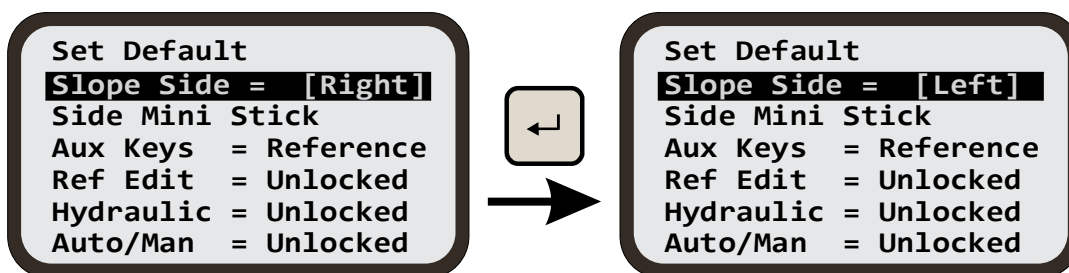

figure 41

5.4 LCD/LED SETTINGS

From the main menu screen, use [AUX2] key to scroll down to 'LCD/LED Settings' and then press [ENTER] key to access the sub menu.

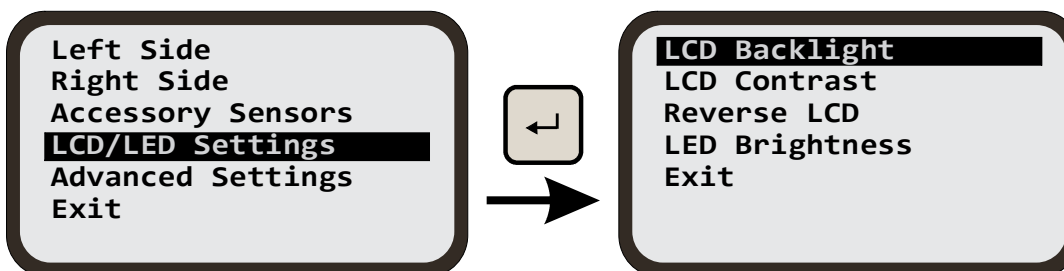

figure 42

5.4.1 LCD BACKLIGHT SETTINGS

From the LCD menu screen, use [AUX2] key to scroll down to 'LCD Backlight' setting and then press [ENTER] key to access the sub menu.

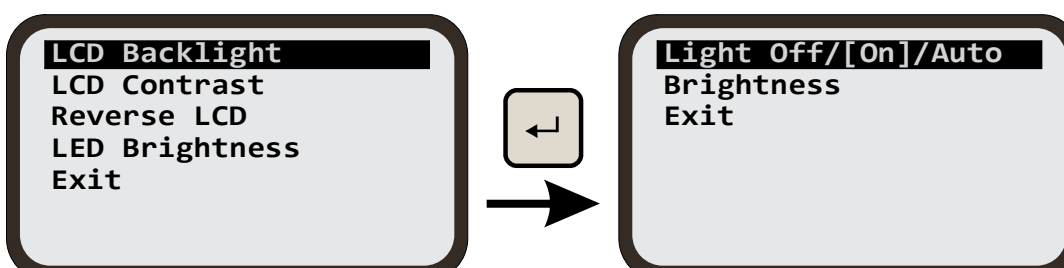

figure 43



5.4.2 BACK LIGHT OFF/ON/AUTO SETTING

With the Light Off/On/Auto option highlighted, press [ENTER] key to select one of three power options for the backlight. The selected setting is shown enclosed in []. The three settings work as below :

1. Off - If this option is selected the backlight will permanently stay off
2. On - If this option is selected the backlight will permanently stay On
3. Auto - If this option is selected the backlight will come on if a key is pressed and automatically switched off after 5 seconds of user inactivity.

Use [AUX2]key to select exit and press [ENTER] key to exit menu.

5.4.3 LCD BRIGHTNESS

Use [AUX2] key to highlight the Brightness setting and then press [ENTER] key to bring up the current brightness settings for LCD.

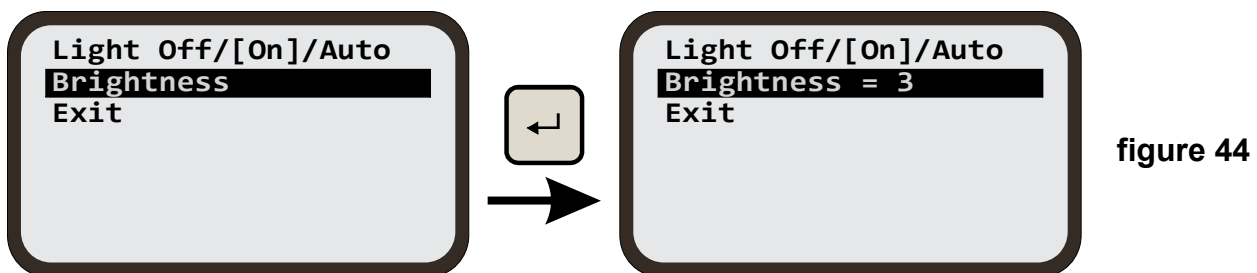

figure 44

The setting will start to blink. Using [AUX2] key, adjust the brightness between four different levels. Adjust the brightness to suit your eyes and cabin light conditions. Press [ENTER] key when done.

5.4.4 LCD CONTRAST

Use [AUX2] key to highlight the 'LCD Contrast' setting and then press [ENTER] key to bring up the current setting.

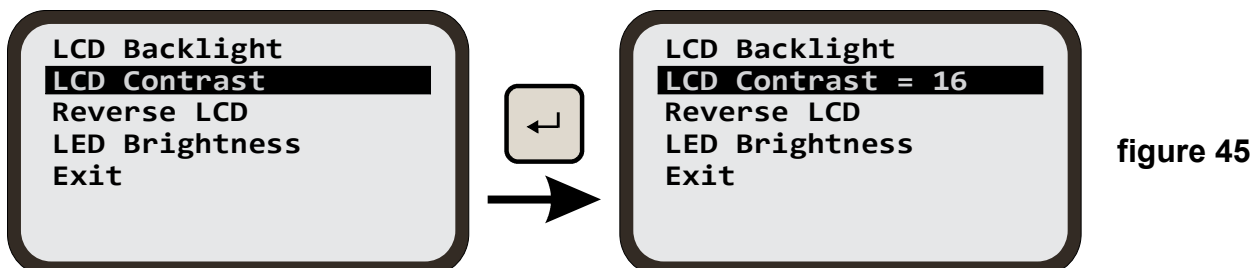

figure 45

The setting will start to blink. Using [AUX2] key, adjust the contrast to suit your eyes and cabin light conditions. Press [ENTER] key when done.



5.4.5 REVERSE LCD

Use [AUX2] key to highlight the 'Reverse LCD' setting and then press [ENTER] key to reverse the default LCD colour settings.

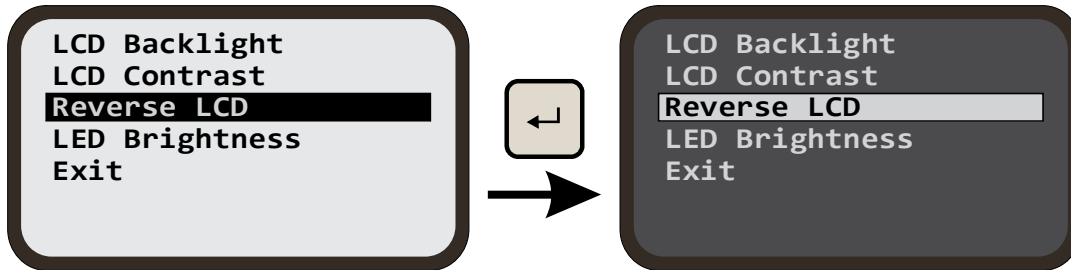

figure 46

5.4.6 LED BRIGHTNESS

Using [AUX2] key to highlight the 'LED Brightness' setting and then press [ENTER] key to show the current 'LED Brightness' level.

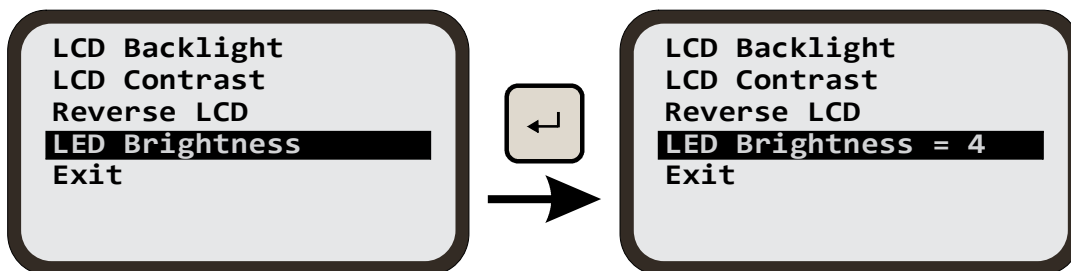

figure 47

The 'LED Brightness' setting will start to blink. And the panel LEDs will turn on to show the brightness.

Using [AUX2] key adjust the 'LED Brightness' to suit your eyes and cabin light conditions.

Press [ENTER] key when done.

5.5 MAST MODE OF OPERATION

5.5.1 MAST WORKING SCREEN

From the main working screen, press [MAST] key to display the mast working screen. The image below shows the current position of the mast in millimeters. In case no mast is connected on either side of the DUO2, a message saying “No MAST” will be displayed.

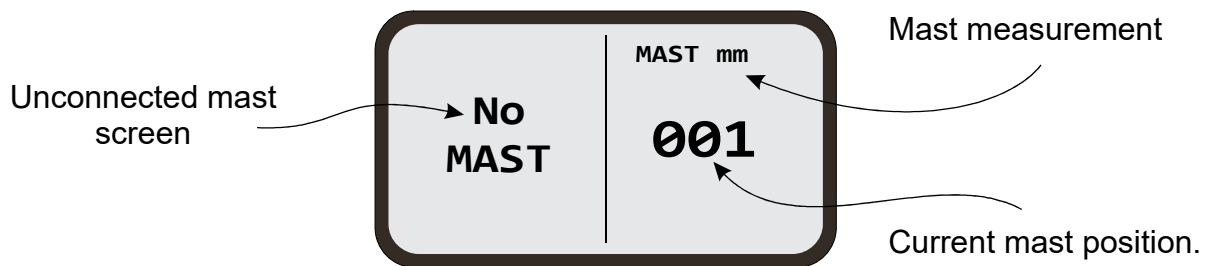

figure 48

5.5.2 MAST FUNCTION KEYS



- Open the reference screen



- Set current mast position as zero



- Press to invoke the mast reference settings.



AUX 2

- Move the mast up and down





5.5.3 ADJUSTING MAST POSITION

Basic mast position adjustment is done with [AUX2] key. Pressing [ZERO] key will set the current mast position to zero.

The reference menu allows to program and memorise 4 positions for quick use in quick position change.

To access the reference menu press the [REF] key from the mast working menu then select a reference slot.

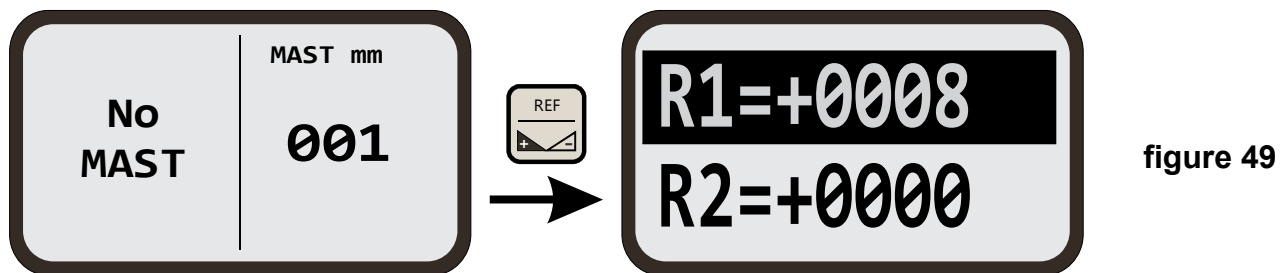

figure 49

After selecting a reference slot press [ENTER] key and the selection will flash. Use [AUX2] key to select and set a new reference point, then press [ENTER] key to confirm the new reference point setting.

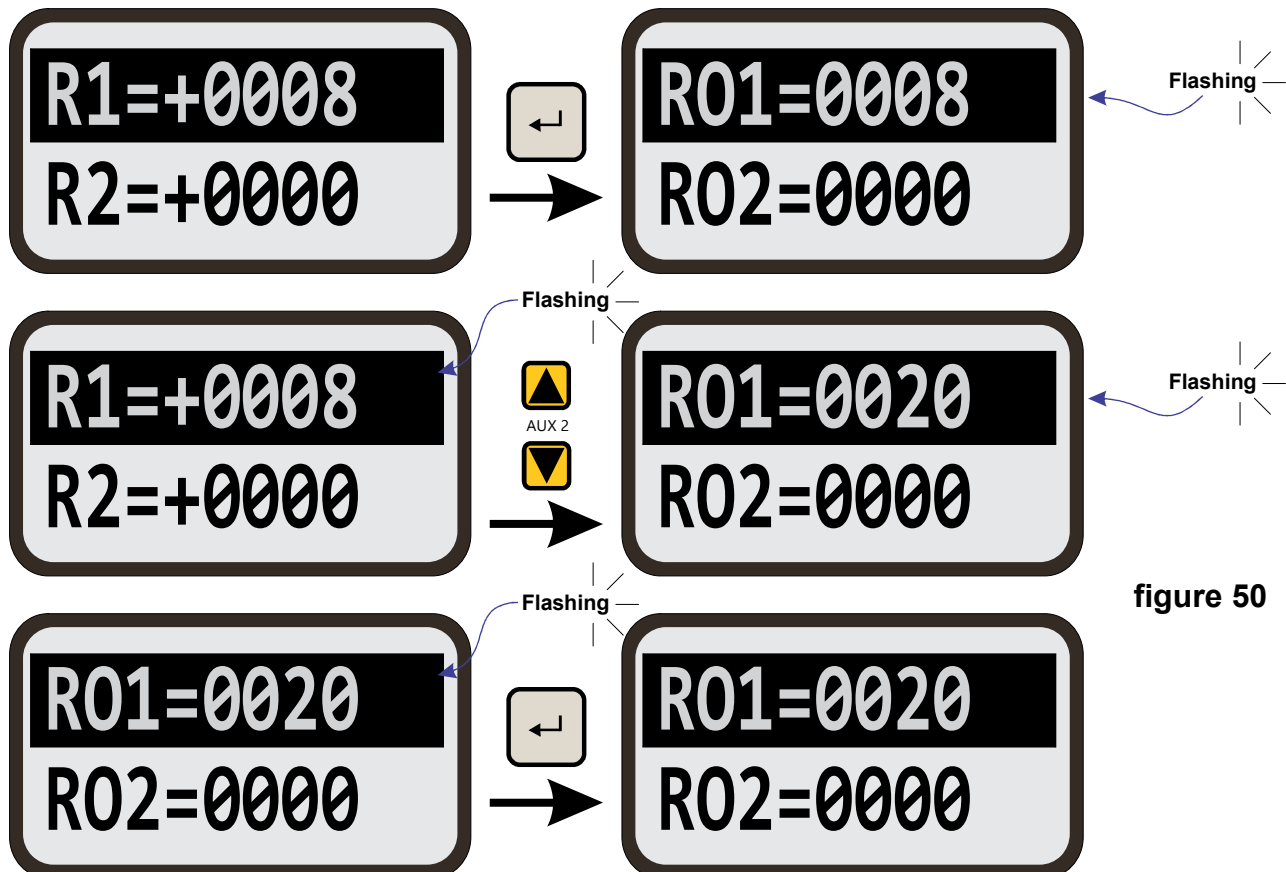

figure 50



5.5.4 RELATIVE OFFSET

5.5.4.1 USING THE PANEL KEYS

The mast can be adjusted to an offset value that is setup in the mast reference offset (RO1 and RO2). To set the offset value;

- 1) Press the [REF] button from the mast working screen.
- 2) Scroll down using the [AUX2] down arrow to select either RO1 or RO2.
- 3) Press the [ENTER] button to enable changes in value to be made.
- 4) Once the value for RO1 and RO2 are set, scroll down using [AUX2] down arrow to exit and press [ENTER] or simply press the menu button to go back to the mast working screen.

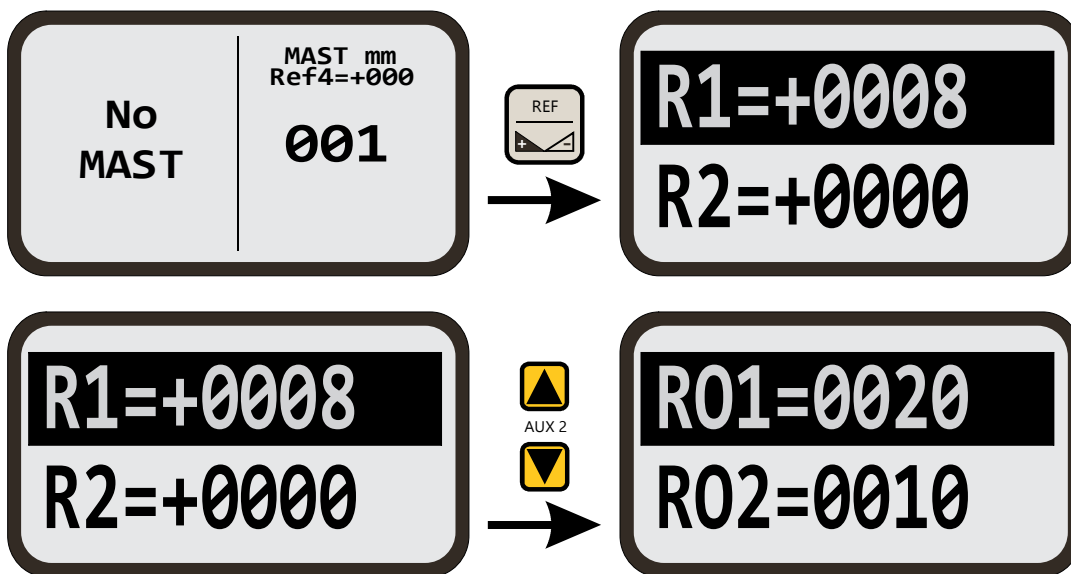

figure 51

To adjust the mast height by RO1 offset;

- 1) Press and hold [REF] button then press the [AUX2] up or down arrow key once to increase or decrease the mast height.
- 2) Upon the release of the [REF] button the mast will move up or down to a value equal to RO1 offset.

To adjust the mast height by multiple of RO1 offset;

- 1) Press and hold the [REF] button then press the [AUX2] up or down arrow key multiple times.
- 2) Upon the release of the [REF] button, the mast will move up or down at a value equal to RO1 offset multiplied by the number of times the [AUX2] up or down arrow key was pressed. A maximum of 7 presses can be made.

Adjusting the mast height by RO2 offset is the same procedure as with adjusting the mast height by RO1 offset.

5.5.4.2 USING OPTIONAL JOYSTICK

An optional joystick can also be used to adjust the mast height by a relative offset, RO1 and RO2. Follow the steps below to take advantage of this feature.

*Note: Relative Offset RO1 and RO2 must **NOT** be set to zero for this function to work.*

The only type of joystick that works using this function is 'Prop Mini Stick/Mast'. To select this type, scroll down to 'Advanced Settings' while in the main menu. Press [ENTER] then scroll down to row 3 for joystick type using [AUX2] down arrow key. Press [ENTER] key to scroll through different types until 'Prop Mini Stick/Mast' is selected. Exit back to the mast working screen.

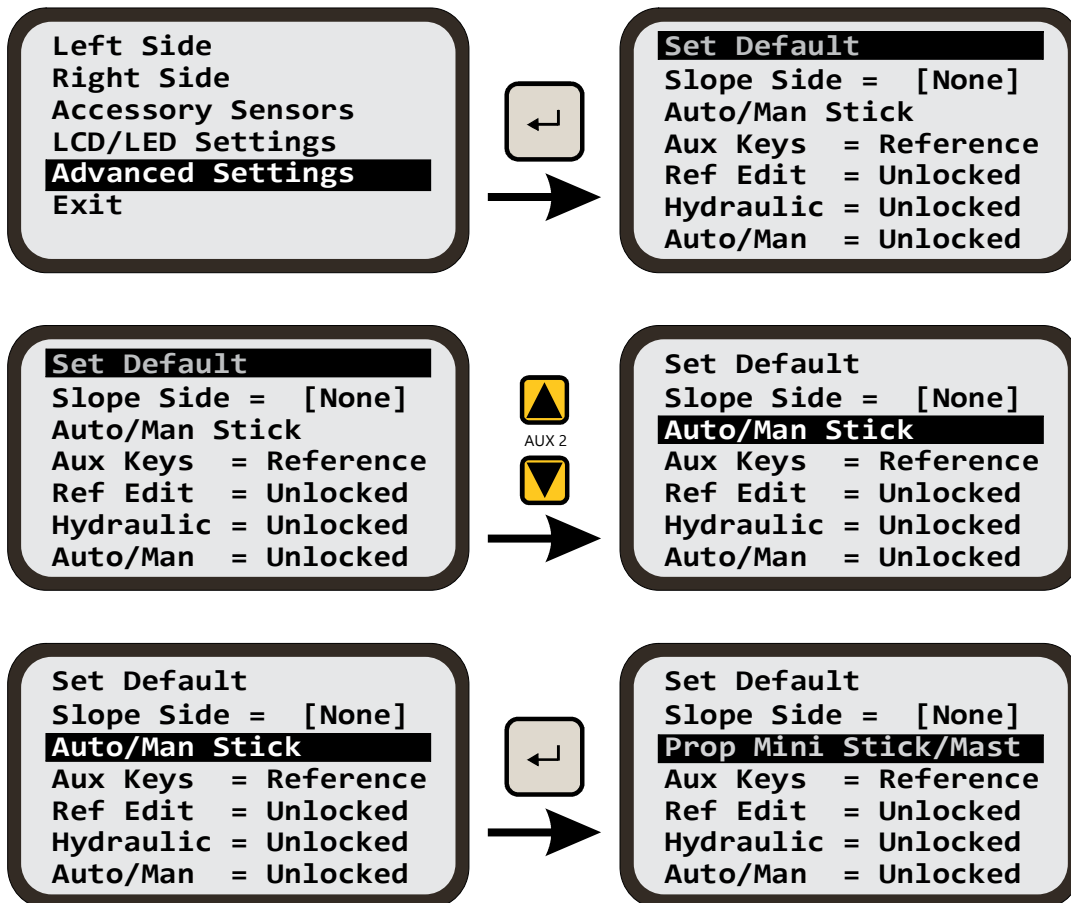
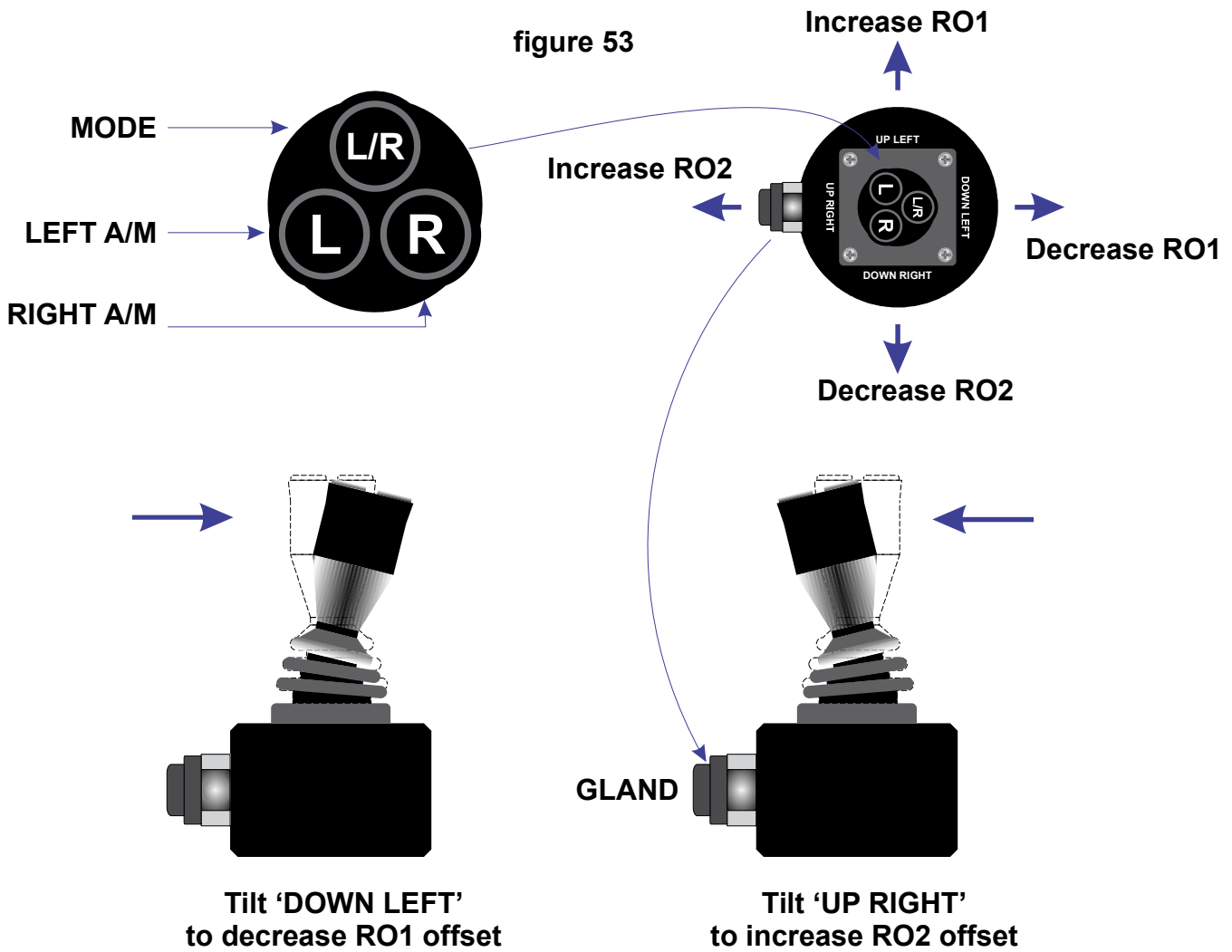

figure 52



figure 53



To increase the mast height by RO1 offset, press and hold [L/R] button then tilt the joystick towards 'UP LEFT' position. While holding the [L/R] button, go back to the neutral position and release the [L/R] button.

To decrease the mast height by RO1 offset, press and hold [L/R] button then tilt the joystick towards 'DOWN LEFT' position. While holding the [L/R] button, go back to the neutral position and release the [L/R] button.

To increase or decrease the mast height by multiple of RO1 offset, press and hold [L/R] button then tilt the joystick towards 'UP LEFT' or 'DOWN LEFT' position and back to neutral position multiple times while holding the [L/R] button. In neutral position, release the [L/R] button to activate. A maximum of 7 tilts can be applied.

Adjusting the mast height by RO2 offset is the same procedure as with adjusting the mast height by RO1 offset. The only difference is the joystick has to be tilted towards 'UP RIGHT' or 'DOWN RIGHT' position.

6. GNSS SENSOR

GNSS sensor enables user to perform land levelling and grading over large area with slightly less accuracy than levelling lasers. It can be used in conjunction with or as a replacement of level lasers.

It supports several Job types, namely Flat Job, Single Slope Job and Dual Slope Job. With Single Slope Job and Dual Slope Job, user only needs to set up 2 height references by driving to the corresponding locations in the field. The required slopes will be calculated by the system automatically.

When installed with slope sensors, DUO2 allows for the target slope of the slope sensor to be automatically calculated based upon the direction in which the machine is traversing, avoiding the inconvenience of regularly changing target slopes when making U-turns during land grading.

6.1 GNSS WORKING SCREEN

The GNSS sensor is always shown on the left side of the working screen. All the information and settings related to GNSS are shown in the typical example below with the GNSS in a fixed state and control panel in manual mode of operation.

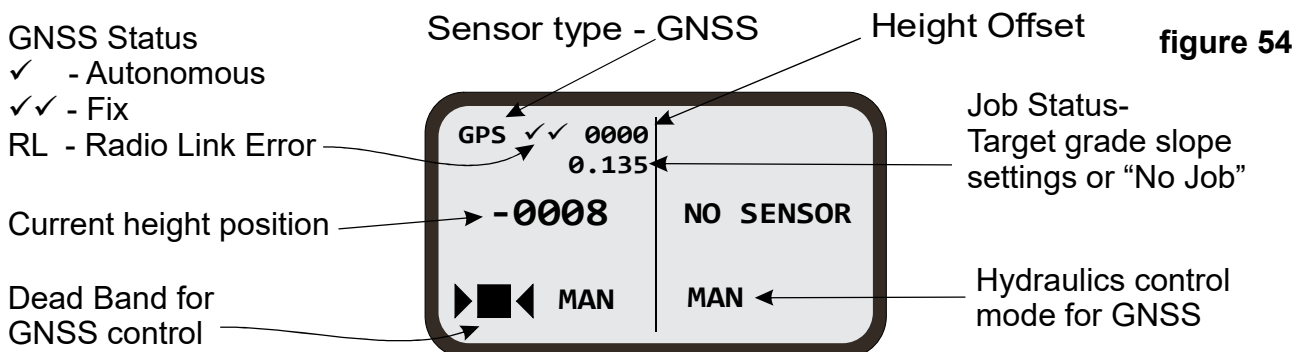

6.2 GNSS FUNCTION KEYS



- Job type selection
- Job target settings



AUX 1

- Move up and down to trim height offset
- Short press both keys to copy current height position to offset



- Long press both keys to reset height and offset to zero



- Zero left side GNSS height and offset



- Edit and select height reference memory settings
 (Long press required in case slope sensor is active on right side of DOU2 to access memory reference settings)



6.3 GNSS JOB TYPE SELECTION & SETUP

Press [ENTER] key to bring up the job selection menu. Select the job type and follow instructions to setup the job direction.

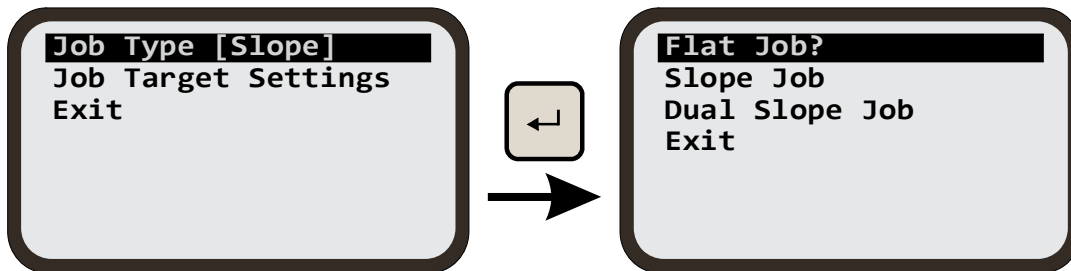

figure 55

To set the job direction enter the position of the two reference points A & B using the following instructions.

Note: For the single & dual slopes provide a minimum distance of 10m between reference points A & B to define accurately the orientation of slope targets.

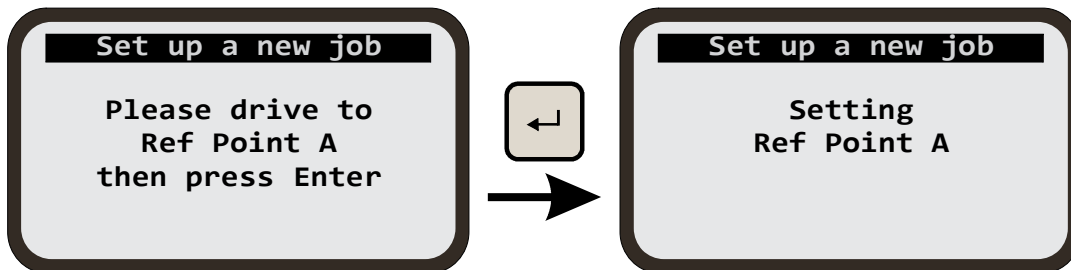

figure 56

Continue with these same steps to set up reference point B.

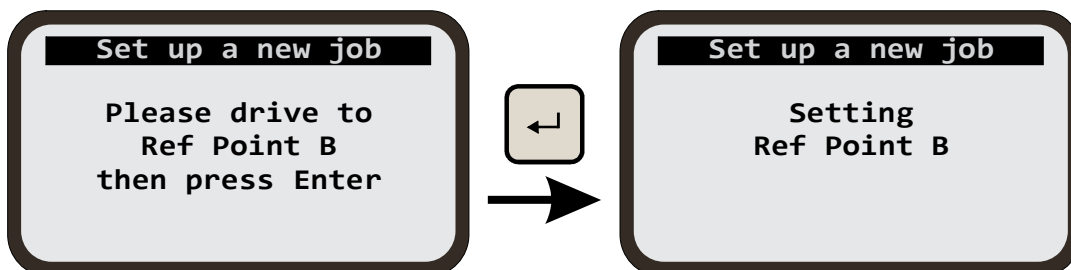
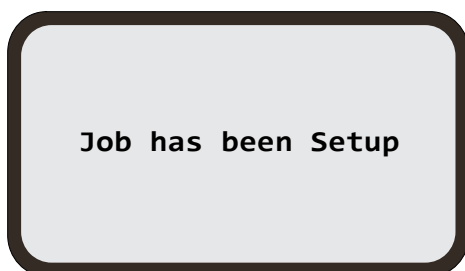
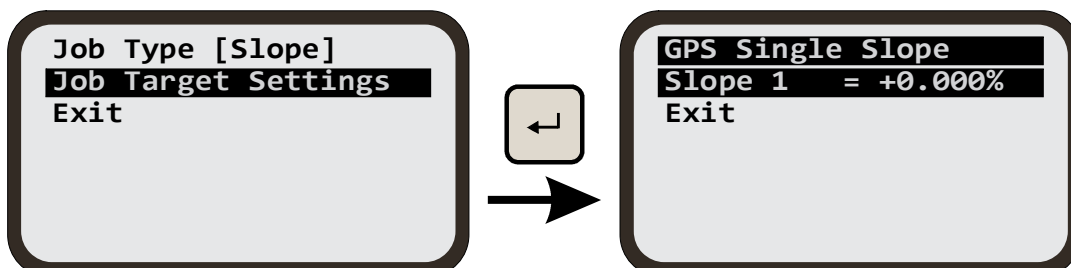

figure 57



Confirm that the job setup has been completed successfully.

For Single Slope and Dual Slope go to the job target settings and use [AUX2] key to configure the required slope settings.





6.4 GNSS AUTO MODE

To enable GNSS Auto Mode, a Dual Slope Job has to be created and the Target Slopes have to be set beforehand. Please refer to Section 6.3 for instructions.

MAKING AVAILABLE GNSS AUTOMATIC MODE

By default, GNSS automatic mode is disabled and not available from the panel. To make this option available, use [AUX2] key to scroll down to 'Advanced Settings' while in the main menu then pressed [ENTER] key to access the submenu.

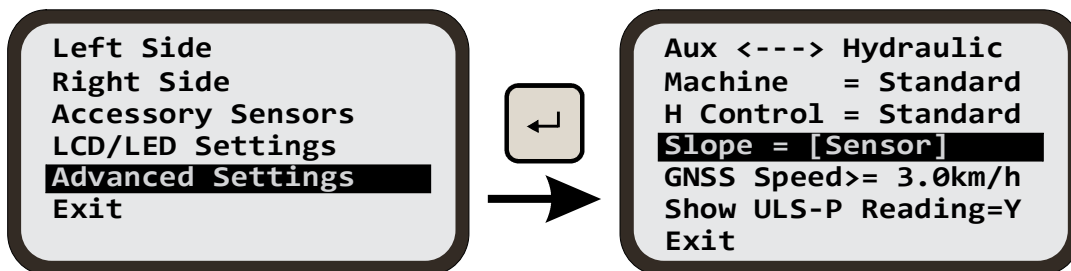

figure 58

In the 'Advanced Settings' submenu, use [AUX2] key to scroll down to 'Slope' option.

Press [ENTER] key to toggle between Sensor and GNSS slope.

To exit the submenu, use [AUX2] key to select Exit and press [ENTER] key to exit the submenu.

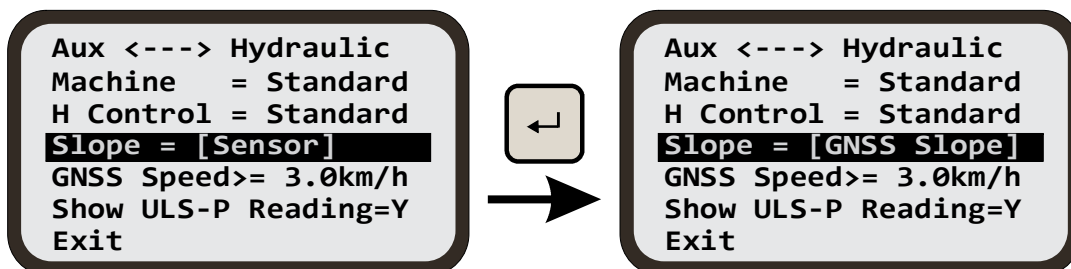
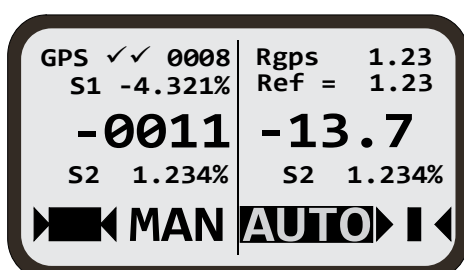

figure 59

ENABLE GNSS AUTOMATIC MODE

After a Dual Slope Job and Target Slopes are set up on the GNSS sensor, press [A/M] key to toggle between manual (MAN) and automatic (AUTO) mode.



Once the GNSS automatic mode is activated, AUTO is highlighted on the slope sensor screen, with the slope sensor's target slope (Ref at the top of the screen) automatically set to GNSS cross slope (S2 at the bottom left of the screen).



7. RESET TO SYSTEM DEFAULT

From the main menu screen use [AUX2] key to select the 'Set Default' option then press [ENTER] key reset all the settings to factory default.

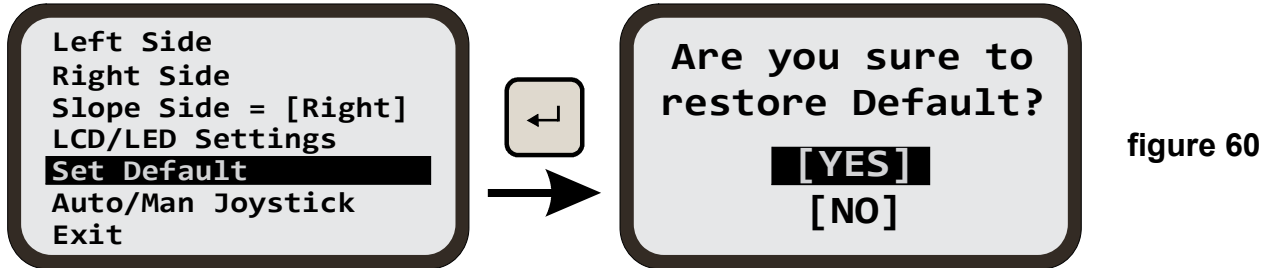

figure 60

To avoid accidental resetting of the system to factory defaults, you will be asked to confirm your selection.

Select '[NO]' using [AUX2] key if you do not want to proceed. Press [ENTER] key to exit.

Select '[YES]' using [AUX2] keys if you want to proceed with system default.

Press [ENTER] key to execute.

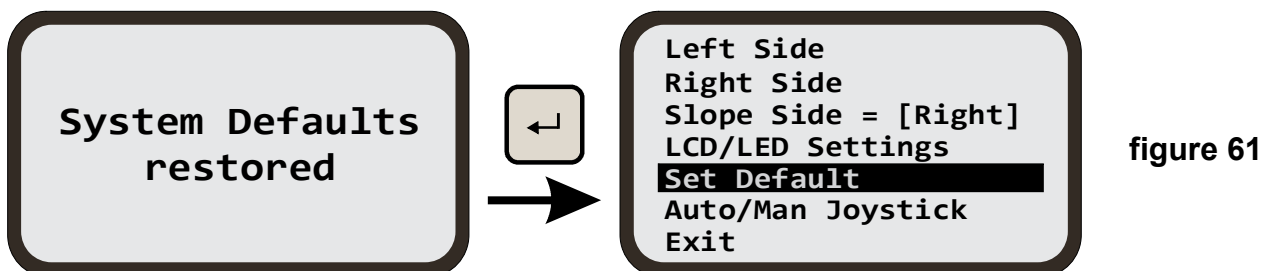

figure 61

Screen will return to the 'Advanced Settings' menu after displaying 'System Defaults restored' for five seconds.

8. JOYSTICK TYPE (optional)

DUO2 supports multiple types of joysticks, so it is very important to select the right type of joystick connected to the system. From the main menu screen use [AUX2] key to scroll down to joystick option and keep pressing the [ENTER] key until the correct type of joystick is shown.

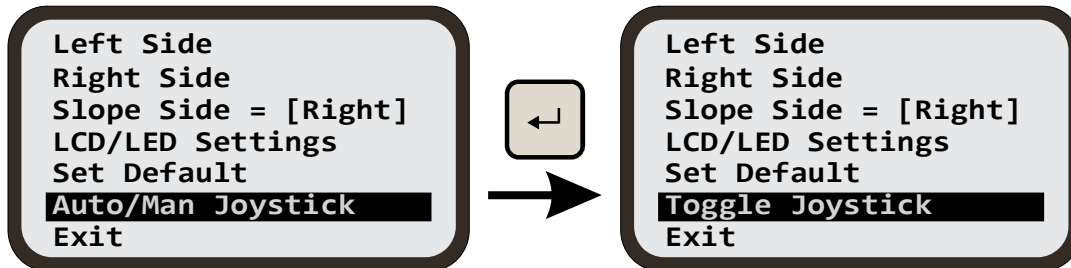

figure 62

The different types of joystick supported are:

(a) Side Mini Stick (default) -

- (i) hydraulic up and down activations for a given side are located on an axis 90 degrees to each other on the joystick handle.
- (ii) Hydraulic activation is proportional to handle position.
- (iii) Includes 3 buttons on top for switching between Auto and Manual:

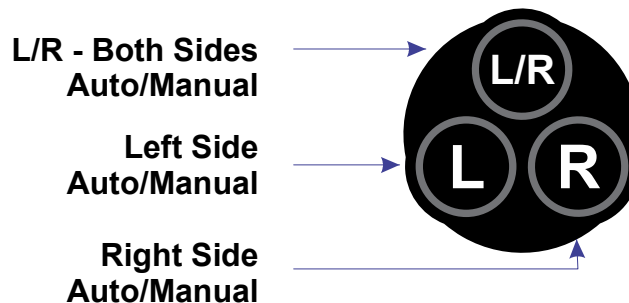
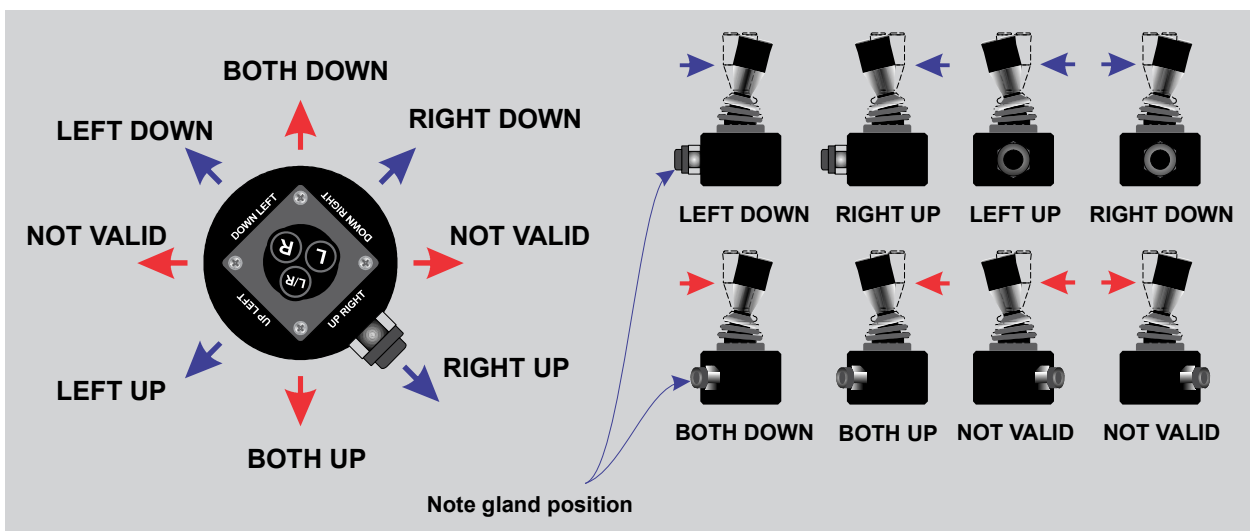

figure 63



(b) Side Mini & Aux Stick - as above with an additional auxiliary hydraulic activation function. This additional auxiliary hydraulic is activated by pressing the L/R button.

(c) Proportional Mini Stick -

- (i) hydraulic up and down activations for a given side are located on the same axis on the joystick handle.
- (ii) Hydraulic activation is proportional to handle position.
- (iii) Includes 3 buttons for switching between Auto and Manual as per side mini stick.

figure 64

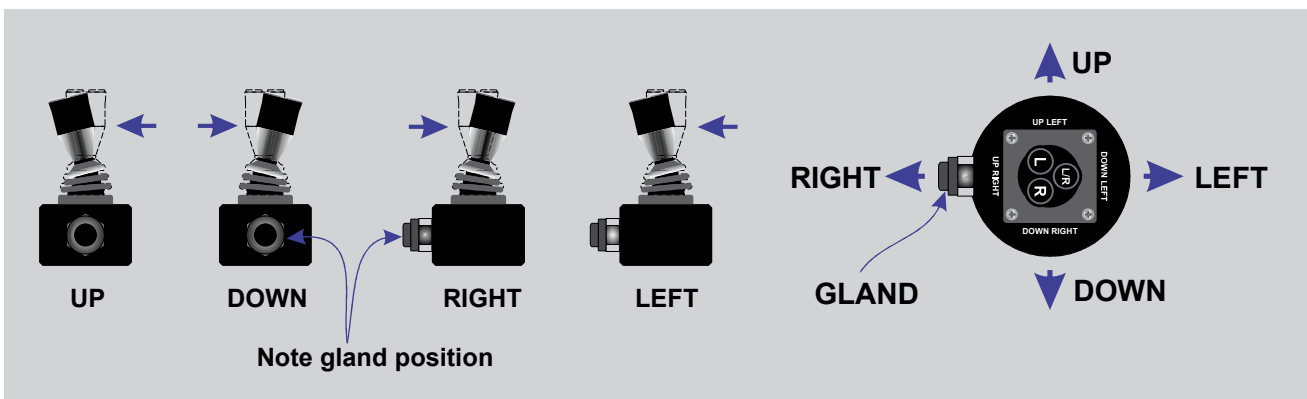

(d) On Off Mini Stick -

- (i) hydraulic up and down activations for a given side are located on the same axis on the joystick handle.
- (ii) Hydraulic activation is not proportional to handle position. Simple ON/OFF activation.
- (iii) Includes 3 buttons on top for switching between Auto and Manual (see fig. 63 on page 49).

(e) Proportional Toggle Stick - works in the same manner as 'Proportional Mini Stick', however power supply and signal out levels differ to accommodate DANFOSS type proportional joysticks (not limited to this brand).

(f) On Off Toggle Stick - works in the same manner as 'On Off Mini Stick', however power supply and signal out levels differ to accommodate DANFOSS type ON/OFF joysticks (not limited to this brand).



(g) Auto/Man Stick - this joystick uses a toggle switch rather than a handle for hydraulic activation and another toggle switch for 'Auto/Manual' selection. Available only for left side.

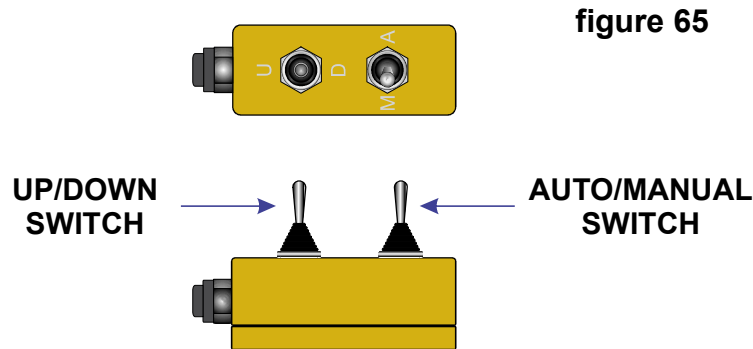

Note: With this option, the [A/M] key on the control panel will not work in the manner described in section 4.2 because the connected joystick will override this button. If no joystick is being used, select 'Side Mini Stick' (the default option).

(h) Mast Offset Stick -

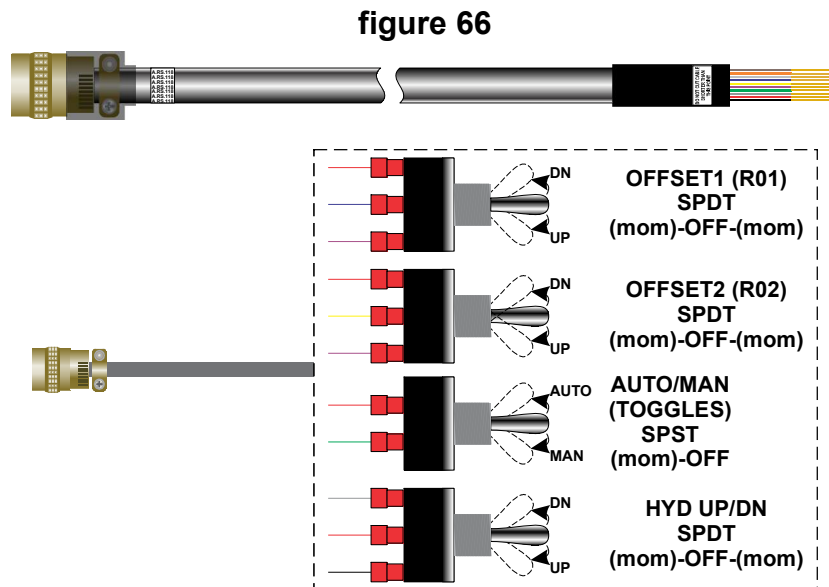

Note: Only cable with bare wires is provided. The switches are **optional**.

(I) Proportional Mini Stick/Mast -



9. PRACTICAL EXAMPLE

The following example is provided to help demonstrate how setting reference offsets, zeroing and mounting would be done in practice. This example involves a trace sensor.

Assume the grading requirement is to maintain a relative distance of -50 mm between the cutting edge of the blade and the top of the curb as shown in figure below.

The user has two ways of achieving the same outcome (please note that the DUO2 should be in manual mode for hydraulic control during the setup phase).

OPTION 1:

1. Position the cutting edge of the blade and the trace sensor as shown, that is, the cutting edge of the blade 50 mm below the top of the curb and the ultrasonic sensor 330-370 mm above the curb (the sensor distance to the curb can be read on the screen while in absolute measurement mode).
2. Set the current offset for the blade to zero.
3. Zero the sensor reading.
4. Switch to AUTO hydraulic control to begin.

figure 67

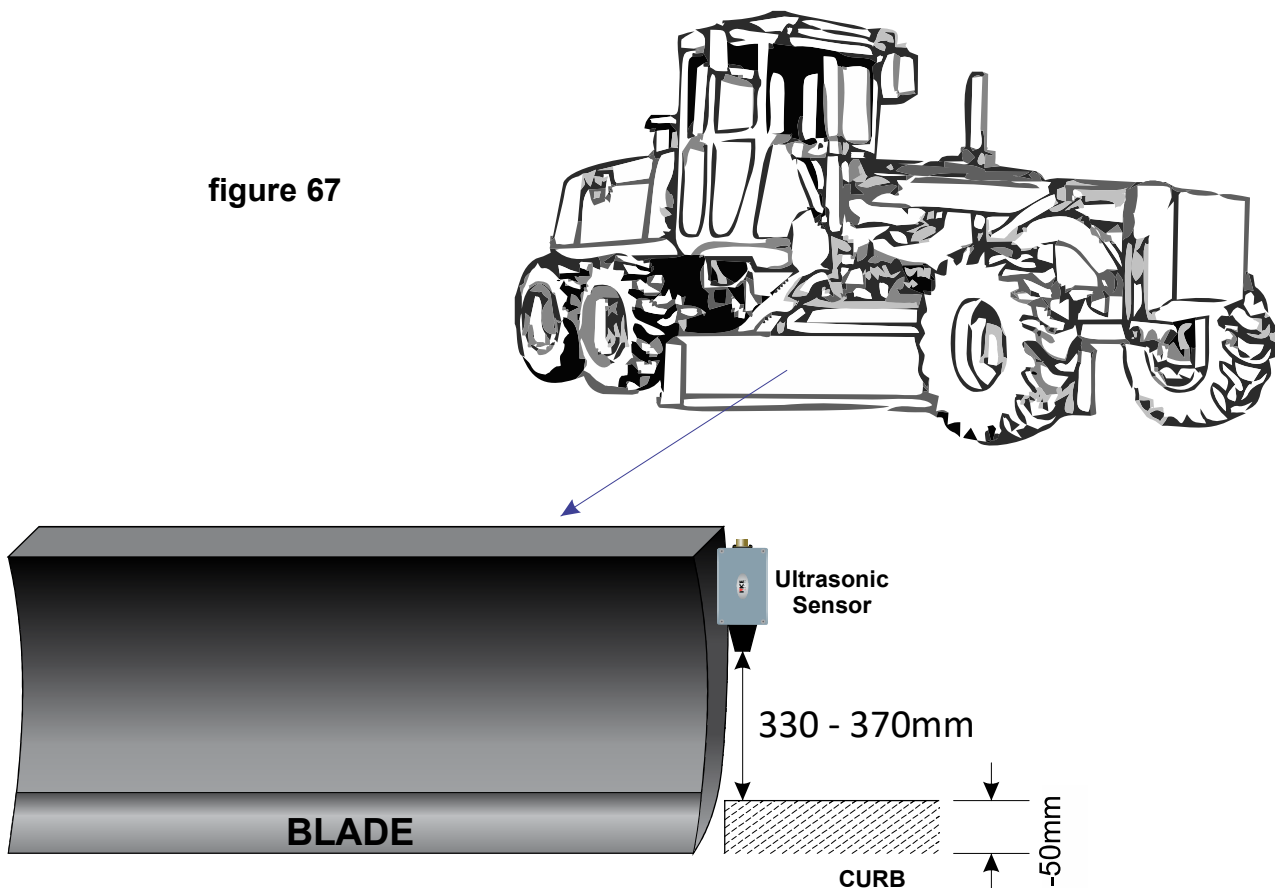

OPTION 2:

1. Position the cutting edge of the blade to be level with the top of the curb and the ultrasonic sensor to be above the curb as shown in the illustrations below. The ultrasonic sensor should be approximately 380-420 mm above the curb, that is, 50 mm above the desired sensor range of 330-370 mm during normal grading operations.
2. Set the current offset for the blade to -50 mm.
3. Zero the sensor reading.
4. Switch to AUTO hydraulic control to begin. The blade will immediately be lowered by 50 mm so that the reading matches the set offset. This will also bring the ultrasonic sensor to a distance of 330 – 370 mm from the curb which is the desired range during normal grading operations.

figure 68

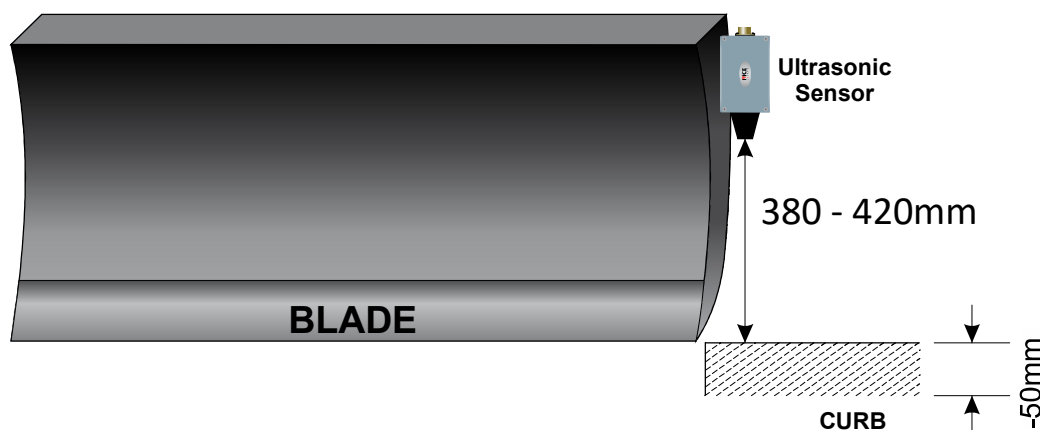

Option 2 should only be used in cases where the desired offset is less than ± 80 - 120 mm so that the tracer is kept within its operating range of 250 - 450 mm when it is mounted in step 1.

In the example above, if the required offset was -200 mm instead of -50 mm, the tracer would have had to be mounted 530 - 570 mm above the curb initially (200 mm above the desired sensor range of 330-370 mm during normal grading operations). This would have put it above its maximum operating range of 450 mm.

Similarly, if the sensor was mounted at 450 mm above the curb initially, it would have ended up at 250 mm when the blade was lowered by 200 mm in step 4. This would have put it right at its minimum operating range which is also not desirable during normal grading operations.



MOBA MOBILE AUTOMATION AUSTRALIA PTY LTD

ABN - 866 279 713 68

90 Willandra Drive, Epping, Victoria, Australia 3076

Ph: +61 3 9357 0055 Email: aumoba@moba.de

www.moba-automation.com.au